

Code of practice
**Safeguarding of
machinery and plant**

2009

commission
for occupational
safety and health

 MIAC

Foreword

This code of practice is issued by the Commission for Occupational Safety and Health (the Commission) and its Mining Industry Advisory Committee under the provisions of the *Occupational Safety and Health Act 1984* (the OSH Act) and the *Mines Safety and Inspection Act 1994* (the MSI Act).

The introduction of the OSH Act enabled the establishment of the tripartite Commission. It comprises representatives of employers, unions and government, as well as experts, and has the function of developing the occupational safety and health legislation and supporting guidance material, and making recommendations to the Minister for Commerce for their implementation. To fulfil its functions, the Commission is empowered to establish advisory committees, hold public inquiries, and publish and disseminate information.

The Commission's objective is to promote comprehensive and practical preventative strategies that improve the working environment of Western Australians. This code of practice has been developed through a tripartite consultative process and the views of employers and unions, along with those of government and experts, have been considered.

The Mining Industry Advisory Committee (MIAC) was established in April 2005 under the OSH Act as a statutory tripartite advisory body on matters relating to occupational safety and health in mining. MIAC's objectives include making recommendations to the Minister for Mines and Petroleum regarding the formulation, amendment or repeal of laws under the MSI Act, and to prepare or recommend the adoption of codes of practice, guidance material, standards and specifications or other forms of guidance for the purpose of assisting employers, self employed persons, employees, manufacturers and others to maintain appropriate standards of occupational safety and health in the mining industry. MIAC may also advise and make recommendations to the Ministers and the Commission on occupational safety and health matters concerning the mining industry.

Legislative framework for occupational safety and health

Occupational Safety and Health Act 1984

The OSH Act provides for the promotion, co-ordination, administration and enforcement of occupational safety and health in Western Australia.

The OSH Act places certain duties on employers, employees, self-employed people, manufacturers, designers, importers and suppliers. It also places emphasis on the prevention of accidents and injury.

In addition to the broad duties established by the OSH Act, the legislation is supported by a further tier of statute, commonly referred to as regulations, together with a lower tier of non-statutory codes of practice and guidance notes.

Occupational Safety and Health Regulations 1996

Regulations under the Occupational Safety and Health Regulations 1996 (the OSH Regulations) spell out specific requirements of the legislation.

Regulations may prescribe minimum standards and have a general application, or define specific requirements related to a particular hazard or particular type of work. They may also allow licensing or granting of approvals and certificates.

Mines Safety and Inspection Act 1994

The MSI Act sets objectives to promote and improve occupational safety and health standards within the minerals industry.

The MSI Act sets out broad duties, and is supported by a further tier of statute, commonly referred to as regulations, supported by non-statutory codes of practice and guidelines.

Mines Safety and Inspection Regulations 1995

The MSI Act is supported by the Mines Safety and Inspection Regulations 1995 (the MSI Regulations), which provide more specific requirements for a range of activities.

Scope and application of this code

In October 2009, the Minister for Commerce approved this code of practice under Section 57 of the OSH Act and in November 2009 the Minister for Mines and Petroleum approved this code of practice under Section 93 of the MSI Act.

This code of practice applies to all workplaces in Western Australia covered by either the OSH Act or the MSI Act. It provides:

- general guidance for employers, designers, manufacturers, suppliers and workers on the identification and control of safety and health hazards and risks associated with guarding, or lack of guarding, of machinery and plant;
- information on key legislative requirements in the OSH Act, the OSH Regulations, the MSI Act and the MSI Regulations as they relate to guarding of machinery and plant; and
- practical guidance on guarding of machinery and plant commonly found in workplaces.

Codes of practice published under the OSH Act and MSI Act

A code of practice is a document prepared for the purpose of providing:

- practical guidance on how to comply with a general duty under the OSH Act and MSI Act or specific duties under the OSH Regulations or MSI Regulations;
- without being prescriptive, practical guidance on safe work practices that can be used to reduce the risk of work-related injury and disease; and
- a practical means of achieving any code, standard, rule, provision or specification relating to occupational safety and health in Western Australia.

A code of practice may contain explanatory information. However, work practices included may not represent the only acceptable means of achieving the standard to which the code refers. Compliance with codes of practice is not mandatory but a code may be used by courts as the standard when assessing other methods or practices used. A code of practice does not have the same legal force as a regulation and non-compliance is not sufficient reason, of itself, for prosecution under the OSH or MSI Act.

Note that there may be additional risks at the workplace not specifically addressed in this code of practice. Under the OSH Act and MSI Act, these must be identified and control measures implemented to prevent or minimise exposure.

Some of the text in this code was originally published by Workplace Health and Safety Queensland © The State of Queensland 2006. It has been reproduced with permission.

Illustrations numbered 21, 25, 26, 27, 30 and 31 are reproduced with the permission of the Queensland Department of Justice and Attorney General (JAG). Copyright of these illustrations is owned by JAG.

Disclaimer

The information contained in this publication is provided in good faith and believed to be reliable and accurate at the time of publication. However, the information is provided on the basis that the reader will be solely responsible for assessing the information and its veracity and usefulness. The State shall in no way be liable, in negligence or howsoever, for any loss sustained or incurred by anyone relying on the information, even if such information is or turns out to be wrong, incomplete, out-of-date or misleading.

In this disclaimer:

- State means the State of Western Australia and includes every Minister, agent, agency, department, statutory body corporate and instrumentality thereof and each employee or agent of any of them;
- information includes information, data, representations, advice, statements and opinions, expressly set out or implied in this publication; and
- loss includes loss, damage, liability, cost, expense, illness and injury including death.

Contents

1.	Introduction and purpose	1
	1.1 Overview of duties	1
2.	Risk management: the three step process	3
	2.1 Step 1: Hazard identification	4
	2.1.1 Examples of hazards	7
	2.2 Step 2: Risk assessment	13
	2.3 Step 3: Risk control	15
	2.4 Holistic approach	17
	2.5 Implementing control measures	17
	2.6 Monitoring and reviewing effectiveness of control measures	18
	2.7 Keeping documents and records	18
3.	Guards and safety devices	19
	3.1 Types of guards	19
	3.1.1 Permanently fixed barriers (guards)	19
	3.1.2 Interlocked physical barriers (interlocked guards)	19
	3.1.3 Physical barrier securely fixed in position (fixed guards)	20
	3.1.4 Physical barriers	20
	3.1.5 Presence-sensing systems	20
	3.1.6 Two handed controls	22
	3.1.7 Combination of guards	22
	3.1.8 Safe system of work for unguarded areas	22
4.	Considerations for designers, manufacturers, suppliers and purchasers	23
	4.1 Responsibilities	23
	4.2 Designing to eliminate or reduce machinery and plant hazards	23
	4.3 Inherently safe design measures	24
	4.4 Considering the life cycle during design	26
	4.5 Basic rules for guard design	27
	4.6 Servicing considerations	28
5.	Guards for different machines	29
	5.1 Exposed rotating cutting machinery	29
	5.2 Pulleys and drives	29
	5.3 Rotating shafts and rollers	30
	5.4 Power take offs (PTOs)	30
	5.5 Power stamping presses	32
	5.6 Press brakes (mechanical and hydraulic)	34
	5.7 Conveyors (bulk handling)	36
	5.8 Robotics	37

6.	Other machinery safety issues	40
6.1	Work organisation	40
6.1.1	Layout	40
6.1.2	Housekeeping	40
6.2	Safe work procedures	40
6.3	Isolation	41
6.4	Emergency stop devices	43
6.5	Controls and buttons	44
6.6	Inspection, cleaning, repair, maintenance and emergency procedures	45
6.7	Weight	45
6.8	Movable guards	45
6.9	Colour coding	45
Appendix 1	Relevant sections of acts and regulations	46
Appendix 2	Other sources of information	47
Appendix 3	Australian and Australian New Zealand standards	49
Appendix 4	Glossary of terms	50
Appendix 5	Ergonomics design principles	52
Appendix 6	Manual handling risks	54
Appendix 7	Risk assessment form	55

1. Introduction and purpose

Inadequate guarding of all types of machinery and plant found in workplaces, such as augers, power take offs (PTOs) and food mixers, has led to serious injuries.

This code of practice has been developed to help people meet their legal obligation to ensure that, as far as practicable, machinery and plant in the workplace are designed safely and adequately guarded so they do not pose a risk of injuries or harm.

This code outlines a range of hazards associated with common machinery and plant, as well as risks that may result from these. Its focus is on the risk management process and providing practical guidance on methods that can be used to guard common machinery and plant at the workplace. It also includes advice on what to consider when designing appropriate guards.

As workplaces and industries have different machinery and plant, it is suggested that the risk management approach be tailored for the unique demands of each workplace and/or industry, as there may be additional hazards and risks not addressed in this code.

What are machinery and plant?

In this document:

- 'machinery' is a collective term for machines and their parts. A machine is considered to be any apparatus that has interrelated parts and is used to perform work; and
- 'plant' is a general name for machinery, equipment, appliance, implement or tool and any component or fitting or accessory of these. It can include things as diverse as presses in a foundry, underground drill jumbos in mining and photocopiers in an office. It can range from electric drills, lifts, escalators, tractors, haulpaks, hand trolleys, cranes, commercial fishing nets to arc welding gear. Fittings, connections and accessories are also considered to be plant.

For further definitions used in this code, see the glossary in Appendix 4.

1.1 Overview of duties

The *Occupational Safety and Health Act 1984* (the OSH Act), *Mines Safety and Inspection Act 1994* (the MSI Act), Occupational Safety and Health Regulations 1996 (the OSH Regulations) and Mines Safety and Inspection Regulations 1996 (the MSI Regulations) impose general and specific obligations on:

- designers of plant;
- manufacturers of plant;
- importers of plant;
- suppliers of plant;
- erectors and installers of plant; and
- employers and employees who use plant at the workplace.

Designers, manufacturers, importers and suppliers

The OSH Act and the MSI Act set out broad duties for people who design, manufacture, import or supply plant for use at workplaces. These duties are to ensure that the design and construction of plant does not expose people who properly install, maintain or use it to hazards.

The OSH Act and the MSI Act also include similar duties for those who design or construct buildings or structures.

General duties at the workplace

All people at the workplace have responsibilities for safety and health at the workplace. The employer's general 'duty of care' obligation is to ensure that, as far as practicable, workers are not exposed to hazards and risks that could arise from machinery and plant, and to address these through a systematic risk management process.

See Section 23 of the OSH Act or, for mining workplaces, Section 14 of the MSI Act. See also Section 4.1 of this code and, for a list of legislation, see Appendix 1.

For more information on the ‘duty of care’ obligations, see the Commission’s guidance note, *General duty of care in Western Australian workplaces* and Resources Safety’s *General duty of care in Western Australian mines — guideline*.

Workers have a responsibility to take reasonable care to ensure their own safety and health and that of others affected by their work.

See Appendix 4 for definition of ‘practicable’ under the OSH Act and the MSI Act.

Providing guards on machinery and plant at the workplace

See regulations 4.37(1)(f) and 4.29 of the OSH Regulations, or for mining industry workplaces, see regulations 4.4(3) and 6.2 of the MSI Regulations.

- Employers, main contractors, self-employed people and people who have control of a workplace or its means of access must ensure that every dangerous part of fixed, mobile or hand held plant is, as far as practicable, securely fenced or guarded. The term ‘as far as practicable’ covers situations in which it would not be practicable to completely guard all dangerous parts of a machine, for example the guide bar and chain on a chainsaw.
- The types of guarding to be provided for different cases and other requirements are contained in the OSH Regulations and MSI Regulations. Some of these are outlined in Section 2.3 of this code.

Consultation

Consultation between employers and workers and, where they exist, safety and health representatives is an important part of the risk management process to identify hazards from machinery and plant and develop measures to eliminate or reduce the associated risks, before an injury or incident occurs.

See Section 19(1)(c) of the OSH Act, or for mining industry workplaces, see Section 9(1)(c) of the MSI Act.

- Consultation is emphasised in the OSH Act and the MSI Act, with an obligation placed on employers to consult workers and, where they exist, safety and health representatives on safety and health. To complement this, workers have a duty to cooperate with their employer on safety and health matters.

Additional information

This code should be read in conjunction with:

- the OSH Act;
- the OSH Regulations;
- the MSI Act (for mining industry workplaces);
- the MSI Regulations (for mining industry workplaces);
- where required, the Australian Standard, *AS 4024 Safety of machinery* series;
- where relevant, Australian Standard, *AS 1755 Conveyors — Safety requirements*;
- relevant manufacturers’ instructions and operators’ instructions and manuals; and
- where they exist, relevant industry codes and guidance notes.

The following Commission guides may also assist:

- *Isolation of plant*;
- *Plant design: Making it safe: A guide for designers, manufacturers, importers, suppliers and installers of plant*;
- *Plant in the workplace: Making it safe: A guide for employers, self employed persons and employees*; and
- *Powered mobile plant: Making it safe: A guide for employers, self-employed persons and employees*.

Useful information may also be found in *Machinery and equipment safety: An introduction* published by WorkSafe.

The above Commission and WorkSafe documents are available at www.worksafe.wa.gov.au

Other sources of information on guarding are listed in Appendix 3.

2. Risk management: the three step process

The OSH Regulations contain a specific requirement for employers to undertake a risk management process.

This involves a three-step process to:

- identify hazards;
- assess risks of injury or harm arising from each identified hazard; and
- control risks through implementation of control measures to eliminate or reduce them.

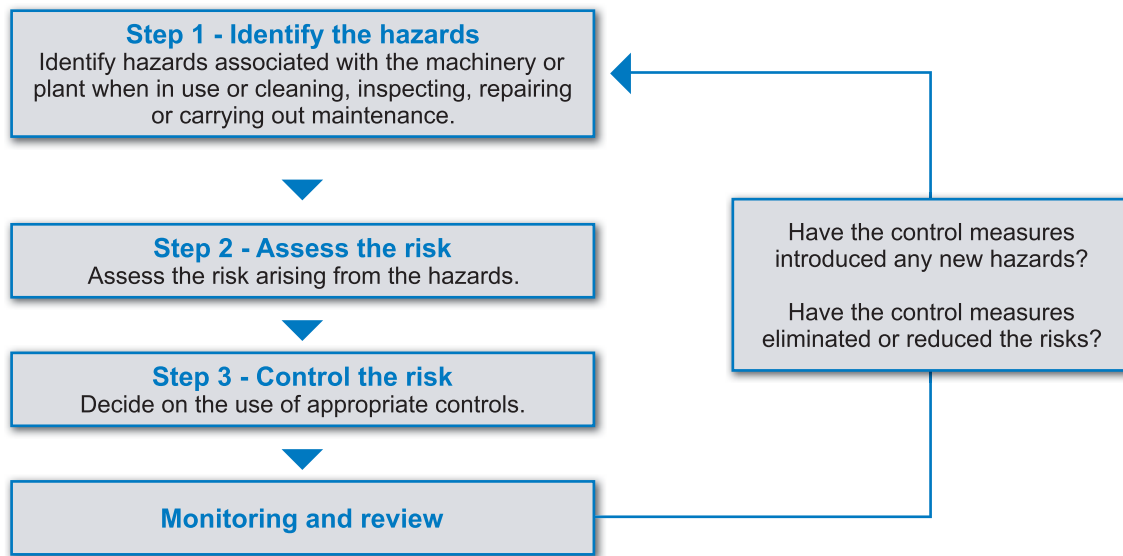

Illustration 1. Risk management steps.

For workplaces covered by the MSI Act, the risk management process should be undertaken to ensure employers comply with their 'duty of care' obligations to provide a safe workplace.

The risk management process should be conducted and monitored on an ongoing basis to ensure control measures are working and no new hazards have been introduced. For example, conducting it when new machinery or plant is introduced, modifications are made to existing plant or machinery or changes are made to systems of work.

Workers and, where they exist, safety and health representatives must be consulted on safety and health matters. Their involvement in the risk management process is important, as they are most likely to know about the risks associated with their work.

See regulation 3.1 of the OSH Regulations.

See Section 9 of the MSI Act.

See Sections 19(1)(c), 23D, 23E and 23F of the OSH Act and Section 9(1)(c) of the MSI Act.

See also the Commission's guide, *Plant in the Workplace: Making it safe: A guide for employers, self-employed persons and employees* and WorkSafe's *Machinery and equipment safety: An introduction*.

2.1 Step 1: Hazard identification

- The first step in the risk management process is identifying hazards. This involves identifying anything that may cause injury or harm to the health of a person.

Identify all machinery and plant used

Start by identifying all items of machinery and plant used at the workplace. An inspection should be carried out looking for any of these items. Include common items that may not normally be thought of as 'machines' or 'plant'.

Identify the hazards

Once all machinery and plant have been identified, the hazards associated with them can be identified.

Three broad sources of hazards

There are three broad sources of hazards relevant to machinery and plant. They are:

- hazards related to the machinery or plant, materials or items being processed or internal sources of energy, for example:
 - drawing in or trapping hazards;
 - entanglement hazards;
 - shearing hazards;
 - cutting hazards;
 - impact hazards;
 - crushing hazards;
 - stabbing and puncturing hazards;
 - friction and abrasion hazards;
 - hot or cold hazards;
 - ejection hazards;
 - other contact hazards;
 - noise hazards; and
 - release of hazardous substances;
- hazards related to the location of the machine or plant, for example:
 - its stability, for instance, whether it could roll or fall over;
 - the environment in which it operates; and
 - its proximity to other structures; and
- hazards related to systems of work associated with the machine or plant, for example manual handling injuries caused when putting materials into them. See Appendix 6.

Critically inspect each piece of machinery and plant and the way it is operated to identify any parts, processes, operating procedures or workplace activities and any related danger zones, such as moving parts of machinery and plant, that may cause harm.

One process to identify hazards is shown in the following diagram.

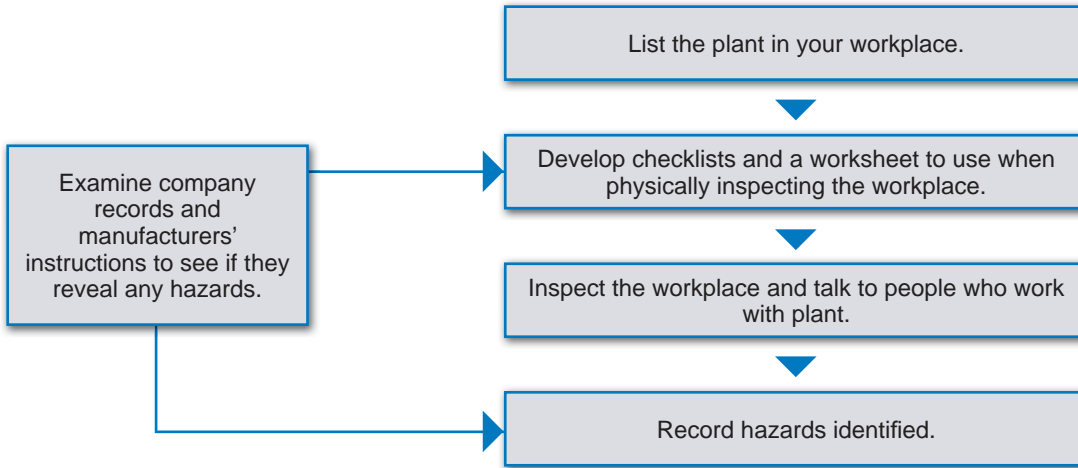

Illustration 2. A process to identify hazards.

Common injuries associated with machines are crushing, cutting, shearing, puncturing, abrasion, burns, tearing, stretching or a combination of two or more of these. Other common injuries include electric shock, hearing loss and ill health from the release of hazardous substances or lack of oxygen.

Common situations resulting in injury or harm to people include:

- coming into contact or entanglement with parts of a machine or plant, for example a worker being drawn into a machine or item of plant or being drawn into a position where they might sustain further injury;
- being caught between a moving section of machine or plant and the material being used to manufacture a product;
- coming into contact or entanglement with material being used in the machine or plant to manufacture a product;
- being caught between a machine, plant, machine part or plant part and a fixed structure such as a wall, column or fixed machine;
- being struck by parts of the machine or plant during its failure or break-up;
- being struck by material ejected from the machine or item of plant; and
- being struck as a result of a release of potential energy in machine components or materials being processed.

Useful guidance on the principles of machinery and equipment safety and risk control can be found in the WorkSafe document, *Machinery and equipment safety: An introduction*.

Factors to consider in identifying machinery and plant hazards

Consider:

- tasks undertaken such as operating, clearing blockages, cleaning, adjusting, setting up, maintaining, repairing or working on a machine or item of plant;
- location such as proximity to other machines and work processes, fixed plant, portable plant and tools;
- installation of the machinery or plant so it is safe and has been done correctly;
- production processes such as forming and finishing;
- walkways and pedestrian access in the vicinity of plant, including access for routing operating and maintenance activities;
- use of mobile plant;
- safe transportation of mobile plant; and
- if appropriate, individual factors such as age, background and self management skills of those who might be operating or come into contact with the machinery or plant and levels of instruction, training and supervision that might be required.

Identifying less obvious hazards

Where machinery and plant hazards are not immediately obvious, activities to help identify them include:

- testing, particularly of plant and other equipment and noise levels;
- using scientific or technical evaluation;
- consulting workers;
- analysing records and data including workers' compensation data, incidents and near misses, hazard reports, sick leave and staff turnover;
- obtaining information from designers, manufacturers and suppliers;
- obtaining information from other organisations such as WorkSafe, Resources Safety, unions, employer bodies and occupational safety and health consultants;
- obtaining specific safety information such as safety alerts or significant incident reports and relevant codes or guides from WorkSafe and Resources Safety;
- in situations where more technical information is sought, using risk assessment techniques, such as Failure Mode Effect Analysis, Hazards and operability (HAZOP) studies and Fault Tree Analysis; and
- carrying out environmental and medical monitoring where required.

Use a wide range of information sources to help identify hazards

Sources of information to help in identifying hazards include:

- consulting workers and, where they exist, safety and health representatives working with the machinery or plant;
- Australian and Australia/New Zealand Standards;
- manufacturers' instructions and advice;
- maintenance logs of machinery or plant;
- documentation relating to safe work practices and their effectiveness;
- injury or incident information and hazard alerts;
- relevant reports from occupational safety and health agencies, unions, employer and professional bodies;
- articles from safety and health journals; and
- safety information from safety authorities on the Internet.

2.1.1 Examples of hazards

Hazards may include, but are not limited to, those shown in the following pages.

Note that the machines and items of plant are shown in their unguarded state to demonstrate the hazards and danger zones.

Drawing-in or trapping hazards

Injuries can be caused when a part of the body is drawn into a 'nip-point', formed by:

- **in-running nips between two counter-rotating parts**, for example meshing gears, rolling mills, mixing rolls and press rolls;
- **in-running nips between a rotating surface and a tangentially moving surface**, for example a power transmission belt and its pulley, a chain and its chain wheel, and a rack and its pinion;
- **running nips between a rotating surface and a tangentially moving surface** where material, for example metal, paper, cable or rope, runs on to a reel, drum or shaft; and
- **nips between rotating and fixed parts**, which create a shearing, crushing or abrading action, as in spoked hand-wheels, flywheels and screw conveyors.

In the context of machinery and plant, 'nip-point' means a point in or around the machine or item of plant with the potential to nip a body part.

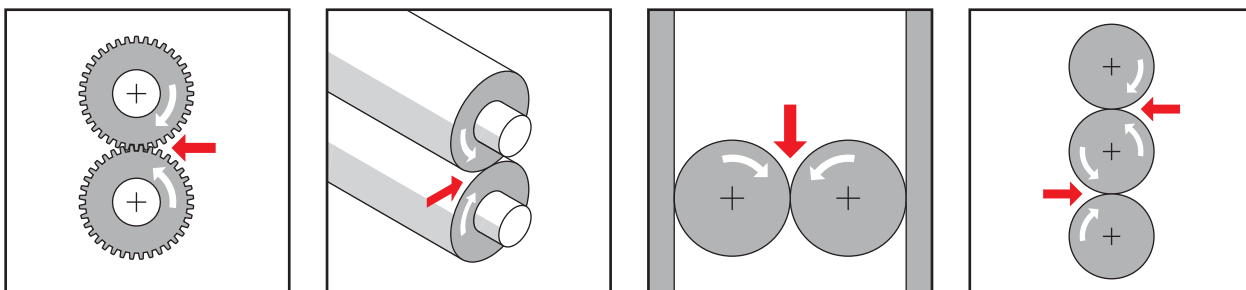

Illustration 3. Drawing-in hazards between counter-rotating parts.
Solid red arrows = where a part of the body could be drawn into a 'nip-point'.
White arrows = movement of machine parts.

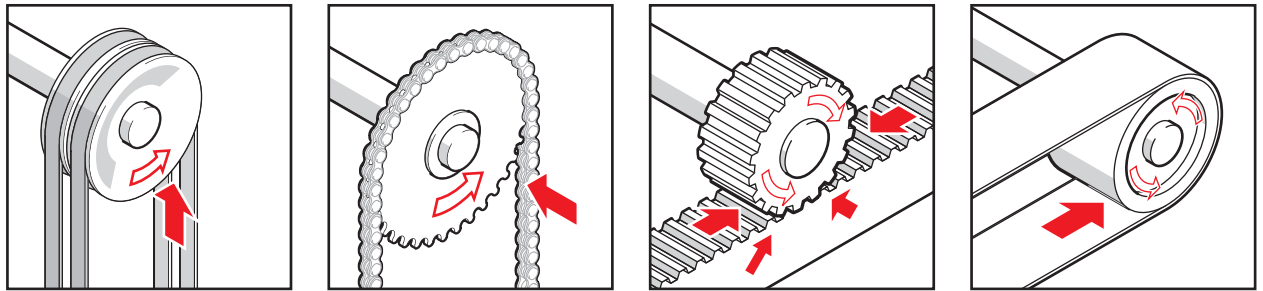

Illustration 4. 'Nip-points' (drawing in hazards).
Solid red arrows = 'nip-points'. White arrows = movement of machine parts.

Entanglement hazards

Entanglement involves being caught in a machine by loose items such as clothing, gloves, ties, jewellery, long hair, cleaning rags, bandages or rough material being fed into the machine. The types of body contact that may lead to entanglement include:

- **contact with a single rotating surface**, for example plain shafting, couplings, spindles, chucks, leadscrews, mandrels or rotating work pieces including plain bar material;

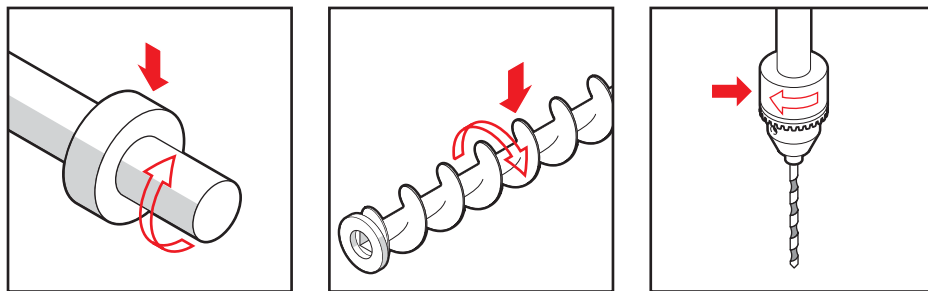

Illustration 5. Contact with single rotating surface.
Solid red arrows = where entanglement can occur. White arrows = movement of machine parts.

- **being caught on projections or in gaps**. Belt fasteners and other projecting items, such as keys, set screws and cotter pins, are typical projection hazards. Fan blades, spoked wheels such as pulleys, sprockets, gear wheels and flywheels, mixer and beater arms and spiked cylinders are gap related hazards;

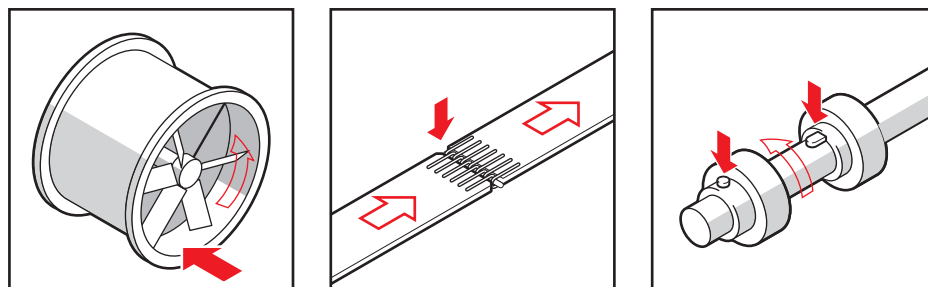

Illustration 6. Catching on projections or gaps.
Solid red arrows = where entanglement can occur. White arrows = movement of machine parts.

- **contact with materials in motion** such as in centrifuges, tumble driers and dough mixers or swarf from machining operations;
- **contact between counter rotating parts**, for example gear wheels or rolling mills;
- **contact between rotating and tangentially moving parts**, for example a power transmission belt and its pulley, a chain and chain wheel, a rack and pinion, a conveyor belt and any of its pulleys and a rope and its storage reel; and
- **contact between rotating and fixed parts**, for example spoked handwheels or flywheels and the machinery bed, screw or worm conveyors and their casings, revolving mixer and mincing mechanisms in casings having unprotected openings, mixers, extruder screw and barrel or the periphery of an abrasive wheel and an incorrectly adjusted work rest.

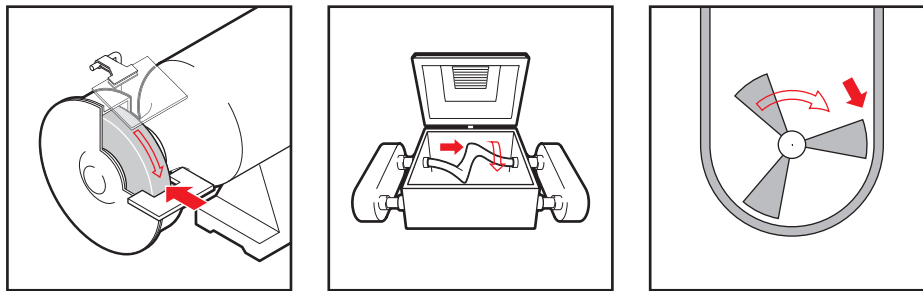

Illustration 7. Catching between rotating and fixed parts.
Solid red arrows = where entanglement can occur. White arrows = movement of machine parts.

No loose clothing, jewellery or long hair

To start addressing the risks from entanglements, requirements that workers not wear loose clothing or jewellery and tie back long hair or wear head covering should be introduced.

Shearing hazards

Shearing action involves applying power to a slide or knife in order to trim or shear metal or other materials. Shear points occur where stock is actually inserted, held and withdrawn.

Parts of the human body can be sheared:

- **between two machine parts**, for example the table of a metal planing machine (shaper) and its bed, the table and blade of a guillotine or power press, nip points between connecting rods or links and rotating wheels or between parts that oscillate; and
- **between a machine part and a work piece**, for example the tool of a broaching machine and the part being broached.

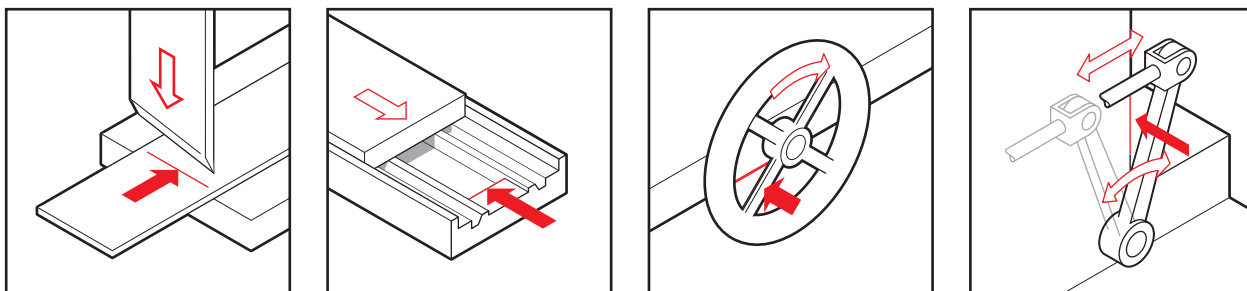

Illustration 8. Shear hazards between two machine parts.
Solid red arrows = where parts of the body can be sheared. White arrows = movement of machine parts.

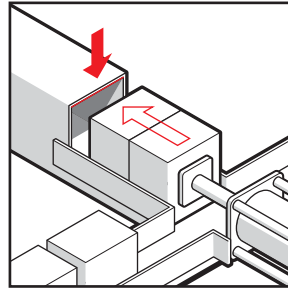

Illustration 9. Shear hazards between a machinery part and a workpiece.
 Solid red arrows = where parts of the body could be sheared. White arrows = movement of machinery part.

Cutting hazards

Cutting hazards are present at the point of operation in cutting wood, metal, or other materials. Examples of mechanisms involving cutting hazards are all kinds of cutting tools, band and circular saws, boring or drilling machines, planing and tenoning machines, milling machines, water jet cutting, high energy lasers or moving sheet material in a machine.

Cutting hazards may involve rotating, reciprocating, or transverse motion. The danger of cutting action exists at the point of operation where finger, arm and body injuries can occur and where flying chips or scrap material can strike the head, particularly in the area of the eyes or face. The cutting effect may be aggravated by the body being unable to move away from the cutter.

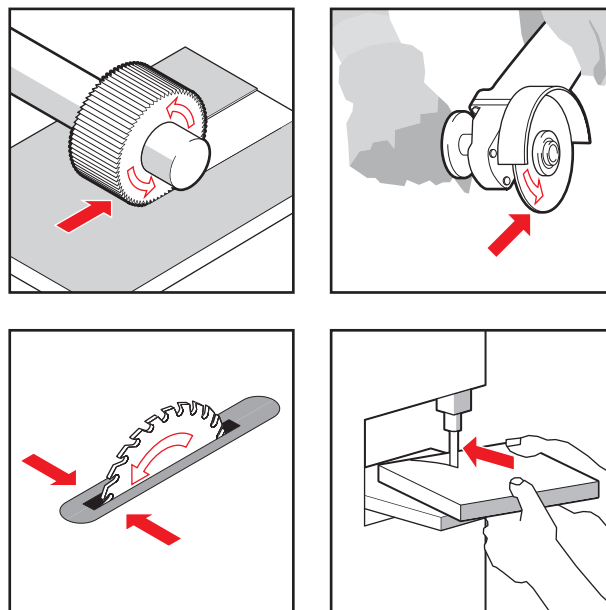

Illustration 10. Typical cutting hazards.
 Solid red arrows = where parts of the body could be cut. White arrows = movement of machinery part

Impact hazards

Impact hazards relate to objects that strike the human body, but do not penetrate it. Examples include the rotating arm of a robot, the reciprocating bed of a metal planing machine and the pendulum movement of the arms of a wool scouring machine.

Impact hazards are different to crush hazards although the machines involved may be the same. Impact hazards operate against the inertia of the body whereas crush hazards involve the trapping of the body between two machine parts or between a machine part and a fixed structure.

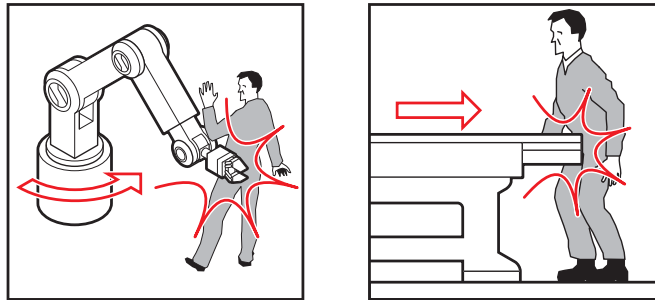

Illustration 11. Impact hazards.
Solid white arrows = movement of machine part.

Crushing hazards

Crushing occurs when a part of the body is caught:

- between a fixed and moving part of a machine such as the bed and tool of a power press;
- between two moving parts of a machine such as the support arms of a scissor lift platform; and
- between a moving part of a machine and a fixed structure such as a counterweight and the floor.

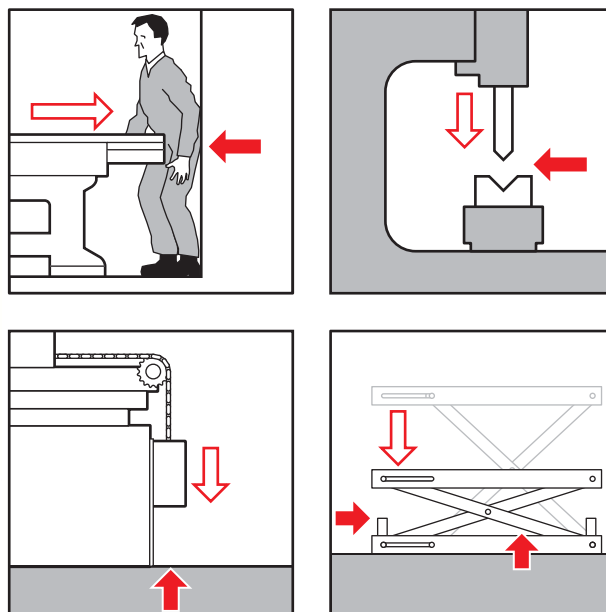

Illustration 12. Crushing hazards.
Solid red arrows = where a part of the body could be crushed. White arrows = movement of machine part.

Stabbing and puncturing hazards

The human body can be penetrated by:

- flying objects such as:
 - parts of a machine, for example a loose tool in a lathe, broken tooling on a press or the breaking-up of an abrasive wheel; and
 - material ejected from a machine, for example swarf, timber from a bench saw, a work piece, molten metal from a diecasting machine, sparks from a welding process, a bolt from an explosive-powered tool or debris thrown by rotary mowers and hedgecutters. Injection of fluids through the skin can cause tissue damage similar to crushing; and
- rapidly moving parts of machinery or pieces of material, for example the needle of a sewing machine, the drill of a drilling machine or the arm of a robot.

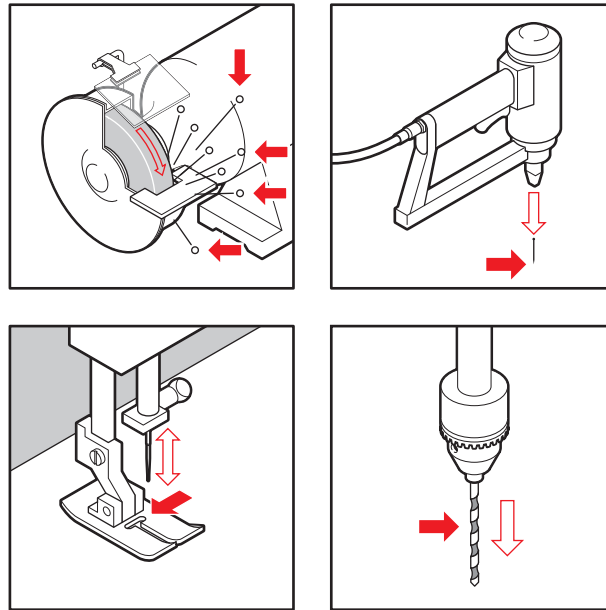

Illustration 13. Stabbing and puncture by flying objects or moving parts of machinery.
Solid red arrows = items that could penetrate the body. White arrows = movement of objects or machine part.

Friction and abrasion hazards

Friction burns can be caused by smooth parts operating at high speed. Other examples of friction or abrasion hazards include the sides of a grinding wheel, the belt of a belt sanding machine, material running onto a reel or shaft, a conveyor belt and its drums, and pulleys and fast-moving ropes or belts.

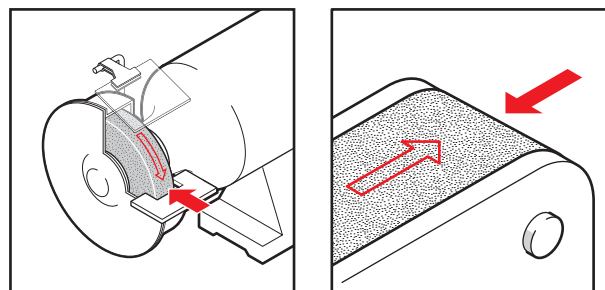

Illustration 14. Friction and abrasion hazards.
Solid red arrows = where a body part may be injured. White arrows = movement of machine part.

Hot or cold hazards

There are a range of hot or cold hazards that may need to be considered including:

- incidents that may occur if people are required to constantly work where the temperature is outside a comfortable range;
- extreme heat or extreme cold, which may affect machinery operations; and
- injuries that may occur if there is contact with hot or cold parts.

Concurrent hazards

Some of the hazards that may arise with machinery or plant may occur at the same time. This should be considered during hazard identification.

Use of physical barriers

Many of the types of hazards illustrated can be effectively managed by the installation of physical barriers. Examples of these are addressed in Section 3 (Guards and safety devices), Section 4 (Considerations for designers) and Section 5 (Guards for different machines) of this code.

Check for specific requirements

Before proceeding to Step 2: risk assessment, check to see if the hazards identified are subject to a specific regulation, code of practice or guidance material issued under either the OSH Act or MSI Act. If so, there may be specific requirements to be taken into account. Details of where to find information are given in Appendix 1 and Appendix 2.

2.2 Step 2: Risk assessment

The second step in the risk management process is assessing the risks of injury or harm arising from the hazards identified in the workplace.

In general, this involves looking at the chance or likelihood of a hazard occurring and, if it does, the extent of any injury or harm, that is the consequences. It is a way of deciding which hazards need to be addressed first, that is where there is the highest risk of injury or harm.

This step should provide information on:

- where, which and how many workers are likely to be at risk of incurring injury or harm;
- how often this is likely to occur; and
- the potential severity of any injuries.

With hazards from bits of moving, rotating or reciprocating machinery, the risk assessment is primarily concerned with assessing the likelihood of a worker getting caught, entangled or nipped and determining the severity of injuries.

Risk factors to consider during the risk assessment include:

- **visibility** — for example, how visible or noticeable is the hazard?;
- **orientation** — for example, a feed screw located low and oriented horizontally would be a risk for hair, tie and jewellery entanglement. One located and/or oriented differently would pose a different risk; and
- **anticipated work practices, including less obvious ones.** These can include:
 - reaching into machines to free blockages/jams or retrieve things. For example, the moving parts in a screw conveyor are behind closed panels, but when a jam occurs, a worker may open the panel and stick their hand in;
 - maintenance, inspection, repair and cleaning practices; and
 - infrequent or one-off tasks required on the plant.

Assessing the risk should therefore take into consideration whether the danger zone can be reached and the likelihood of a worker extending fingers, hands, arms, feet or legs into places where they do not go during normal machine operation.

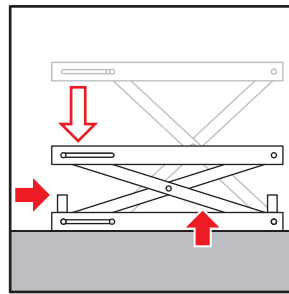

Illustration 15. An example of visibility risk factor. When the top part of the machine lowers, it comes to rest on supports on each corner, so only a small area on the underneath of the top may be a hazard. Solid red arrows = where body part may be injured. White arrows = movement of machine part.

Adequate information, knowledge and experience

Risk assessment is not an absolute science — it is a ‘best estimate’ made on the basis of available information. Therefore, it is important that:

- the people undertaking a risk assessment have the necessary information, knowledge and experience of the work environment and work process, or such a person is involved; and
- workers and safety and health representatives are consulted as they may be able to advise on the particular hazards and risks associated with different machinery or plant.

This enables you to be systematic in determining the ‘best estimate’.

If required, Australian Standards AS 4024.1301 and AS 4024.1501 in the Australian Standard, AS 4024 *Safety of machinery* series contain further information on risk assessment factors and methodology.

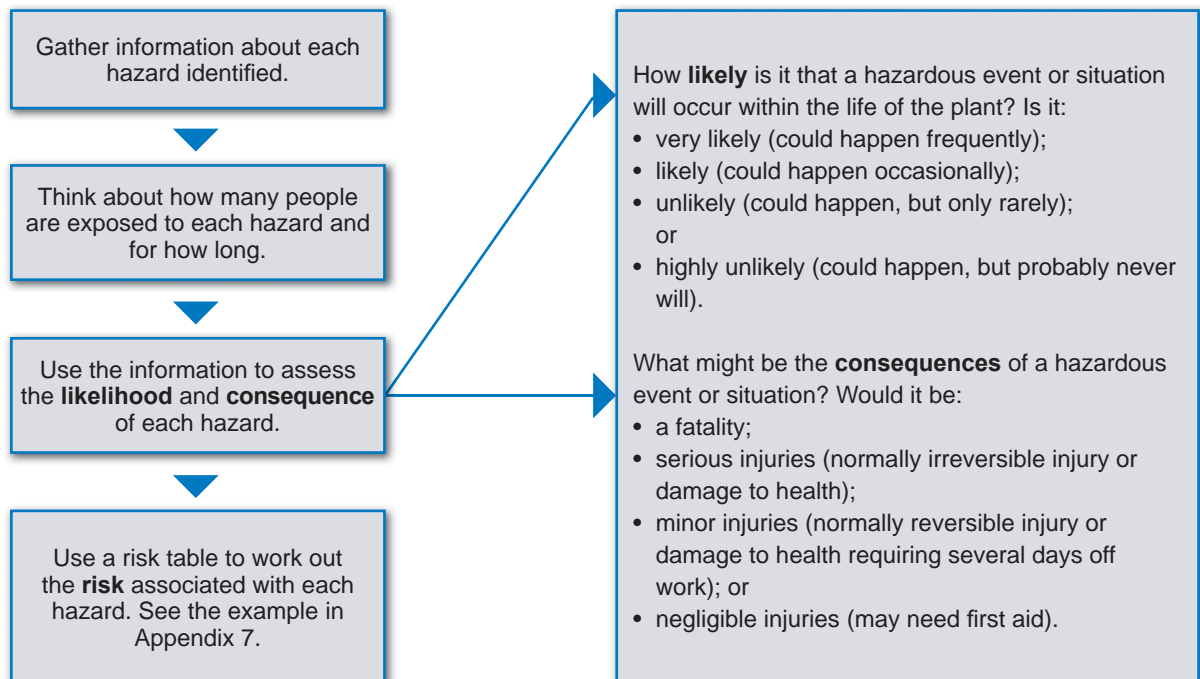

Illustration 16. Risk assessment.

Priorities

Once hazards have been rated, a prioritised list of workplace risks requiring action can be developed.

Risk assessment form

A risk assessment form is included in Appendix 7. This will help to assess the risks posed by machinery and plant.

It is suggested that one form be used per machine or part of a machine if there are several hazards. This form may be adapted for other activities relevant to machines in the workplace, such as purchase, installation, maintenance or work processes.

2.3 Step 3: Risk control

The third step is to implement control measures to eliminate or reduce the risks of a person being injured or harmed and ensure the measures are monitored and reviewed on an ongoing basis.

When considering risk control, there is a recommended order of control measures to implement, ranging from the most effective to the least effective, to eliminate or reduce the risks of injury or harm. This is also referred to as the 'hierarchy of control'. It is:

- elimination;
- substitution;
- isolation;
- engineering controls;
- administrative controls (for example, work practices that reduce the risk such as providing procedures and instruction); and finally
- personal protective clothing and equipment — these should only be considered when other control measures are not practicable or to increase protection. While essential for some work procedures, these should be last in the list of priorities.

The above control measures may be used in combination.

See regulations 4.37 and 4.29 of the OSH Regulations or, for mining industry workplaces, regulations 6.17, 6.18 and 6.2 of the MSI Regulations.

Provision of secure fencing or guarding to control risks

With the control of risks that could arise from unguarded machinery or plant, there are specific requirements in the legislation for the implementation of control measures.

Employers, main contractors, self-employed people and people who have control of a workplace or its means of access must **ensure that every dangerous part of fixed, mobile or hand held plant is, as far as practicable, securely fenced or guarded** in accordance with regulation 4.29 of the OSH Regulations or, for mining industry workplaces, regulation 6.2 of the MSI Regulations (see below) unless the machinery or plant is positioned or constructed so it is as safe as it would be if securely fenced or guarded.

Hierarchy of guarding

Regulation 4.29 of the OSH regulations or, for mining industry workplaces, regulation 6.2 of the MSI regulations require that the above people must ensure that, where guarding should be provided for machinery or plant, it comprises:

- a permanently fixed physical barrier for cases in which, during normal operation, maintenance or cleaning of the plant, no person would need either complete or partial access to the dangerous area;
- an interlocked physical barrier for cases in which during normal operation, maintenance or cleaning of the plant, a person may require complete or partial access to the dangerous area;
- a physical barrier securely fixed in position by means of fasteners or other suitable devices sufficient to ensure that the guard cannot be altered or removed without the aid of a tool or key for cases where neither a permanently fixed physical barrier or an interlocked physical barrier is practicable; or
- if none of the above guards is practicable, a presence-sensing safeguard system; however,
- where guarding of any moving part of the machinery or plant does not eliminate the risk of entanglement or it is not practicable to guard it, the above people must ensure that workers or other people do not operate or pass close to the moving part unless **a safe system of work is in place** to reduce the risks as far as practicable.

Other guarding requirements

The above people must also ensure that:

- fences or guards provided are **constantly maintained** and of **substantial construction** taking into account their intended purpose; and
- as far as practicable, any fence or guard provided is **kept in position** while the machinery or plant is operated.

Note that Part 4, Division 4 of the OSH Regulations or, for mining industry workplaces, Part 6, Division 2 of the MSI Regulations contain additional requirements in relation to safety of plant.

Additional controls

Even when one or more control measures have been implemented, additional controls might also be required, such as administrative controls or personal protective clothing and equipment.

Administrative controls or use of personal protective clothing or equipment should not be relied upon as the primary means of risk control. They are dependent on human behaviour and require management, enforcement and commitment to work effectively.

Administrative controls may be used as an interim measure until higher level controls are implemented or used in tandem with more effective control measures.

Examples of administrative controls are managing the time and hours of work, who does the work and who has access to work areas, machinery or plant. Other examples include training workers in the proper procedures and processes for operating machinery or plant and limiting exposure or the amount of time spent doing hazardous work activities.

Personal protective clothing and equipment means clothing, equipment or substances that, when worn correctly, protect part or all of the body from risks of injury or disease at work or in the workplace, for example protective eyewear, protective hearing devices, sturdy gloves or mesh gloves to prevent cutting injuries.

2.4 Holistic approach

The risk management process of identifying hazards, assessing the risks and implementing controls should be holistic. For example:

- interaction between a combination of hazards and its effect on the level of risk should be assessed;
- in some instances it may be acceptable to have a higher risk rating for a hazard or hazards provided the implemented control measure(s) address the overall risk to a higher degree; and
- a potential hazard may not necessarily require a single matching control. A response could be to implement a control measure that addresses a number of potential hazards.

2.5 Implementing control measures

Activities necessary to allow the selected control measures to function or operate effectively include:

- **developing work procedures** — these should be developed in relation to chosen control measures to ensure their effectiveness. Management, supervision and worker responsibilities should be clearly defined. In relation to use of machine safeguarding, the procedures should, at a minimum, cover:
 - arrangements for ensuring the appropriate guarding is purchased and correctly installed;
 - arrangements for provision of instruction, supervision and training of workers to ensure the machinery is only operated with the guarding in place;
 - the requirement for workers to follow instructions;
 - arrangements for maintenance of the machine and safeguards; and
 - arrangements for workers to report malfunctions or problems with machinery;
- **consultation and communication** — workers and, where they exist, safety and health representatives must be consulted and informed about the control measures to be implemented and of any changes to these arrangements. Information may also need to be provided to others who may enter the workplace, including cleaners, visitors and contract staff;
- **provision of training and instruction** — training and instruction must be provided as necessary for workers, supervisors and others to enable them to use the control measure so they are not exposed to hazards. This information should be provided to workers in a manner that is readily understood, with special consideration given to language and literacy issues;
- **supervision** — adequate supervision must be provided as necessary to ensure that the control measures are being used correctly; and
- **maintenance** — work procedures should clearly identify maintenance requirements to ensure the ongoing effectiveness of the control measures. Looking at maintenance of control measures is an important part of the implementation process.

2.6 Monitoring and reviewing effectiveness of control measures

Having implemented control measures, it is important that they be regularly monitored and reviewed.

Questions to ask

In monitoring and reviewing control measures, it is useful to ask:

- have control measures been implemented as planned?
- if control measures have not been implemented, why not?
- are the control measures being used and, if so, are they being used correctly?
- are control measures working?
- have changes made to control exposure to the assessed risks resulted in what was intended?
- have implemented control measures resulted in the introduction of any new hazards?
- have implemented control measures resulted in the worsening of any existing hazards?

In order to answer these questions, there may be a need to:

- consult with workers, supervisors and, where they exist, safety and health representatives;
- measure levels of exposure, for instance take noise measurements in the case of isolation of a noise source;
- refer to manufacturers' instructions;
- monitor incident reports; and
- contact industry associations, unions, government bodies or safety and health consultants.

In determining the frequency of the monitoring and review processes, consider:

- the level of risk — high risk hazards need more frequent assessments;
- the type of work practices or plant involved;
- a regular review of the process for hazard identification, risk assessment and risk control to ensure the risks are effectively managed; and
- further review of control measures when new methods, tasks, equipment, hazards, operations, procedures, rosters or schedules are introduced, the environment changes or there is any indication risks are not being controlled.

2.7 Keeping documents and records

It is advisable to record the chosen control measures. If a preferred control measure cannot be implemented immediately, the controls intended as short-term and longer term solutions, along with the proposed implementation timeframe, should be recorded.

Keeping records helps track what has been done or what is planned and assists in maximising the effectiveness of the process.

Adequate recording of the risk management process undertaken in regard to machinery and plant helps demonstrate compliance with legal obligations. The level of documentation should be appropriate for the level of risk and control measures.

The OSH Regulations and the MSI Regulations include **specific requirements to keep records** of any maintenance, inspection, commissioning, alteration or test results for **certain types of plant**. There are also requirements related to information provided by suppliers of plant and obligations for transfer of information upon sale of the plant. These obligations are mandatory.

See regulation 4.34 of the OSH Regulations or, for mining industry workplaces, regulation 6.25 of the MSI Regulations.

3. Guards and safety devices

3.1 Types of guards

As outlined in Section 2.3 of this code, the OSH Regulations and the MSI Regulations contain set requirements for certain types of guards to be provided for particular cases.

The range of guards includes, but is not limited to, permanently fixed physical barriers, interlocked physical barriers, physical barriers securely fixed in position, and presence-sensing systems. Examples are outlined below.

Depending on the situation, a combination of two or more of the following guards may be required to ensure workers' safety.

If required, there is additional information in Australian Standard AS 4024, *Safety of machinery series* on types of guards and categories of reliability.

3.1.1 Permanently fixed barriers (guards)

'Permanently fixed barriers' are permanently fixed physical barriers that are welded or incorporated into the body of the machine for cases in which, during normal operation, maintenance or cleaning, no person would need complete or partial access to the dangerous area.

3.1.2 Interlocked physical barriers (interlocked guards)

'Interlocked physical barriers' (interlocked guards), such as enclosure guards, are known as 'movable guards' and are interconnected with the power or control system of the machine. The interlock prevents the machinery from operating unless the guard is closed. They cannot be opened until the dangerous parts of the machine have come fully to rest.

Interconnections are usually mechanical, electrical, hydraulic or pneumatic. They provide an effective safeguard where access to the point of operation is required between each cycle of the machine or regular access is needed.

In the event of electrical failure, loss of power or malfunction, the machine's guarding system should 'fail to safe', and render the machine or part inoperable until the power is restored or the guarding mechanism is repaired.

Interlocked guards and their components must be designed so that any failure does not expose people to danger. The design also needs to consider the possibility of a person being inside the area covered by the guard when an attempt is made to start the machine.

See also the WorkSafe bulletin number 5/2006, *Food preparation mixer guarding*.

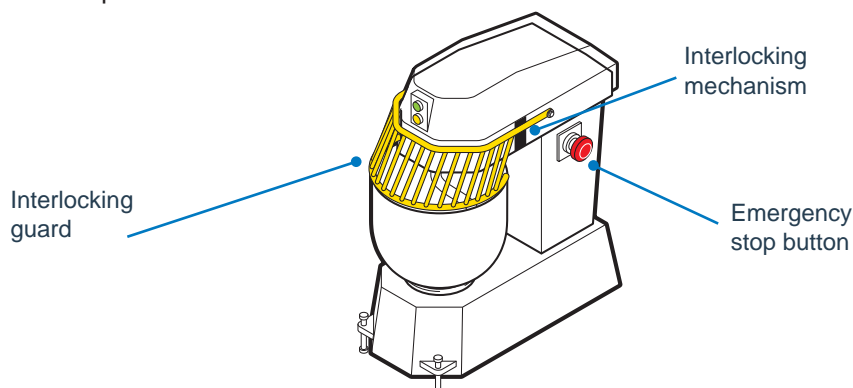

Illustration 17. Food mixer with an interlocking guard.
Yellow = guarding. Red = emergency stop button.

The type of safety device installed with the guard, and the level of integrity of the related control circuitry, can only be determined after conducting a risk assessment. If required, Australian Standard, AS 4024.1501 *Safety of machinery: Part 1501: Design of safety related parts of control systems — General principles for design* contains additional information.

3.1.3 Physical barrier securely fixed in position (fixed guards)

'Physical barriers securely fixed in position' (fixed guards) should be easy to remove and replace but only with the aid of a special tool such as a spanner, Allen key or similar tool and only when the machine is not in operation. Wing nuts, wedge inserts or similar fixing devices, which can be operated with the fingers or become stuck, should not be used.

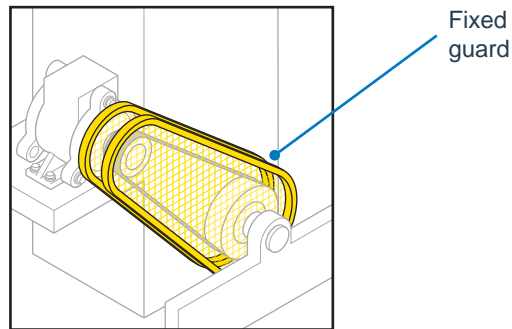

Illustration 18. Example of a fixed guard. The design of guards may have to take into account the need to adjust drive belts and transmission chains. Yellow = guarding

3.1.4 Physical barriers

Sufficient physical barriers or fences securely fixed in position by means of fasteners or other suitable devices may prevent access to dangerous areas. Any access points through the barrier, for example gates and doors, should be secured with a lock or interlocking system.

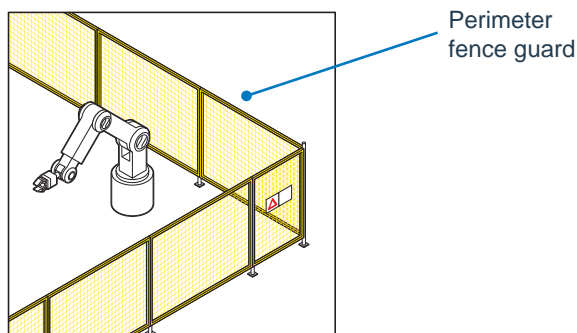

Illustration 19. Perimeter fence guard with fixed panels and interlocking access door. Yellow = guarding

With physical barriers, there is a danger of machines activating while a person is close to them, such as when an interlocked door is accidentally closed and re-activates the machine. For further information on isolation procedures, see Section 6.3 of this code.

3.1.5 Presence-sensing systems

There are two types of presence-sensing guards. These are:

- **laser guards**, which are photoelectric safety systems that detect an obstruction in the path taken by a beam or beams of light. If the field of light is broken, the machine stops and will not cycle. The invisible barrier operated by this system may consist of a single beam, multiple of beams of light, a curtain of light or any combination of these necessary to provide the required safeguard. This device should be used only on machines that can be stopped before the worker can reach the danger area; and
- **light guards**, which are light beams used in guarding of machinery. They may be a scanning beam or beams, or a number of fixed beams. The light may be visible or invisible, for example infra-red, and may be continuous or modulated.

When properly maintained, presence-sensing systems stop the machine before a person moves into a position where they could be injured, that is before access can be gained to a dangerous area surrounding the machine.

The systems can prevent a person or part of the body gaining access to a dangerous area of the machine as a result of the design, placement or junction of machine controls. They rely on sensitive trip mechanisms and the machine being able to stop quickly, which may be assisted by a brake.

Photoelectric curtains, laser scanners and pressure mats are examples of these types of guards.

Effective presence-sensing safeguard systems require selection of a trip device appropriate for the work being done, and the correct location of beams with light activated devices, taking into account speed of entry and machine stopping time.

Presence-sensing safeguard systems must be operated and maintained according to the manufacturers' instructions.

Records must be kept of any maintenance, inspection, commissioning and alteration to a presence-sensing system, as well as any test results, while it is at the workplace. These records are required to be accessible at all reasonable times to workers and, where they exist, safety and health representatives at the workplace.

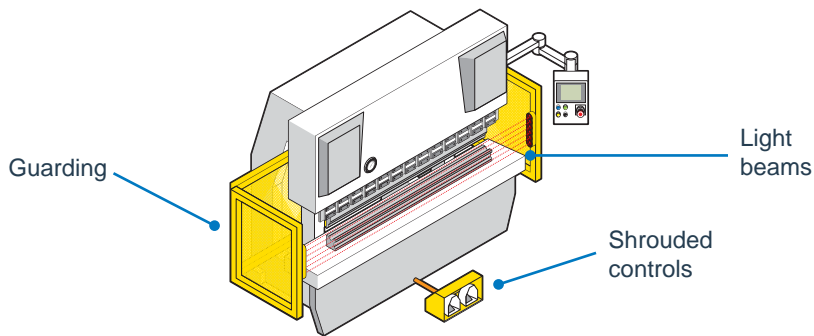

Illustration 20. Example of a photoelectric light curtain used as a trip guard. When any of the beams is blocked by intrusion towards the hazard area, the light curtain control circuit switches off the power to the hazard.

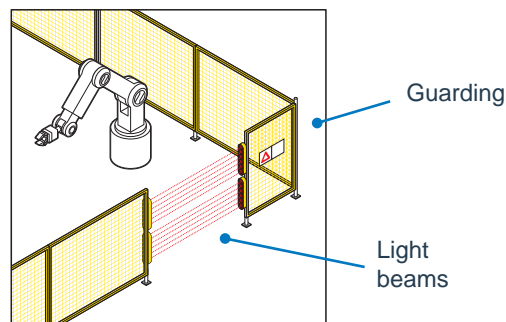

Illustration 21. Example of a photoelectric light curtain used as a trip guard. When any of the beams is blocked by intrusion towards the hazard area, the light curtain control circuit switches off the hazard power.

Yellow = guarding. Red = light beams.

Where required, see Australian Standard, AS 61508.1 *Functional safety of electrical/electronic/programmable electronic safety-related systems — General requirements* for more information in relation to safety integrity levels.

See regulation 4.34 of the OSH Regulations or, for mining industry workplaces, regulation 6.25 of the MSI Regulations.

3.1.6 Two handed controls

Two-handed control devices force the operator to use both hands to operate the machine controls. However, they only provide protection for the operator and are usually easy to defeat. They do not provide protection for anyone else who may be near the danger point.

Two-handed controls should only be used in conjunction with other guarding types and not on their own. Guards installed must be arranged to protect all people, as far as practicable.

Where two-handed controls are provided, they should be spaced well apart and/or shrouded. The machine should only operate when both controls are activated together and the control system should require resetting between each cycle of the machine.

It should not be possible to tape or weigh down one of the control buttons, nor should it be possible to operate one button with the knee, elbow, forehead or foot.

3.1.7 Combination of guards

There may often be a need for more than one type of guarding system to ensure the safe operation of machinery or plant.

Illustrated below is an example where a combination of guarding and safety devices has been used.

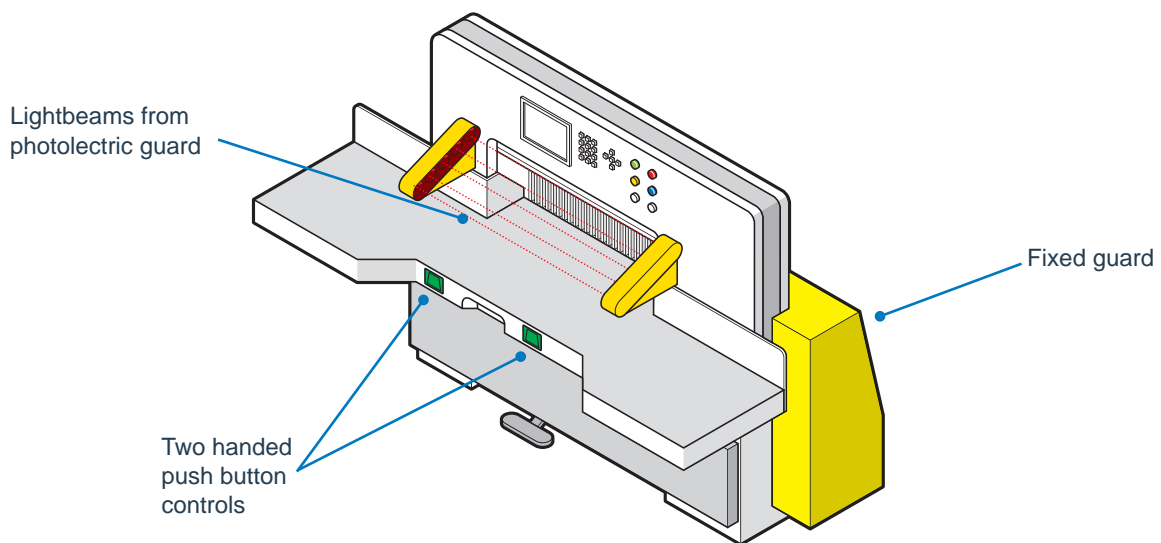

Illustration 22. Paper cutting guillotine featuring a combination of guarding and safety devices with a photoelectric guard, fixed guards and two-handed push button controls.
Yellow = guarding. Red = photoelectric guard

3.1.8 Safe system of work for unguarded areas

In cases where guarding of any moving part does not eliminate the risk of entanglement or where it is not practicable to guard it, the law requires workplaces to ensure that people do not operate or pass close to the moving part unless a safe system of work is in place to reduce the risks as far as practicable

See regulation 4.37(i) of the OSH Regulations or, for mining industry workplaces, regulation 6.27(1)(b) of the MSI Regulations.

4. Considerations for designers, manufacturers, suppliers and purchasers

4.1 Responsibilities

The OSH Act and the MSI Act set out broad duties for those who design, manufacture, import or supply plant or machinery to ensure they are safe. The OSH Regulations and the MSI Regulations also contain specific requirements for these people.

Designers have a responsibility to assess and control the risks associated with the plant or machinery they design and provide safety information about them to manufacturers.

Manufacturers of machinery and plant have a responsibility to follow the designer's specifications precisely in order to ensure they are as free from risks as the designer intended. Under some conditions, for example if the designer is outside Western Australia, the manufacturer in Western Australia takes on the designer's responsibility to make sure the risks associated with the design are assessed and controlled.

The manufacturer also has a responsibility to provide particular kinds of safety information to users of the machinery or plant.

People who import machinery and plant into Western Australia take on the responsibility of the designer and manufacturer to ensure the risks associated with the plant are assessed and controlled, and provide the required safety information to users.

Suppliers of machinery and plant are responsible for making sure the risks to safety and health from the plant they supply are eliminated or minimised. Suppliers who also import the plant they supply take on the importer's responsibility to ensure the whole risk management process is carried out.

The general duties of a supplier apply to hirers and leasers of plant for use at a workplace. In between hirings and leasings, the supplier must ensure the plant is inspected and maintained to reduce, as far as practicable, any risk of injury or harm. They must also provide safety information to people hiring or leasing the plant.

For non-mining workplaces, see Section 23 of the OSH Act and regulations 4.23 and 4.30 of the OSH Regulations. For mining workplaces see Section 14 of the MSI Act and regulations 6.3, 6.4 and 6.5 of the MSI Regulations.

For non-mining workplaces, see Section 23 of the OSH Act and regulations 4.24, 4.30A and 4.31 of the OSH Regulations. For mining workplaces, see Section 14 of the MSI Act and regulations 6.6, 6.7 and 6.8 of the MSI Regulations.

For non-mining workplaces, see Section 23 of the OSH Act and regulation 4.31 of the OSH Regulations. For mining workplaces, see section 14 of the MSI Act and regulations 6.9, 6.10 and 6.11 of the MSI Regulations.

For non-mining workplaces, see Section 23 of the OSH Act and regulation 4.33 of the OSH Regulations. For mining workplaces, see Section 14 of the MSI Act and regulations 6.12 and 6.13 of the MSI Regulations.

For non-mining workplaces, see Section 23 of the OSH Act and regulation 4.35 of the OSH Regulations. For mining workplaces, see Section 14 of the MSI Act and regulation 6.14 of the MSI Regulations.

4.2 Designing to eliminate or reduce machinery and plant hazards

Considering ways to eliminate or reduce hazards in the engineering design of machinery and plant can eliminate many risks to safety and health. Similarly, consideration of design during manufacture and purchasing can eliminate or significantly reduce the chances that people using the machinery or plant will be harmed.

Design-related hazards may relate to the characteristics of the plant itself, the application and associated work practices, as well as the working environment in which it will be operated.

Common categories of hazards that should be considered in machinery design include:

- **mechanical hazards** — for example hazards created by the shape, relative location, mass and stability, kinetic energy and material strength;
- **electrical hazards** — factors include contact with or proximity to live parts, suitability of insulation, electrostatic phenomena, thermal radiation and consequences of overloads or short circuits;
- **thermal hazards** — for example contact with high temperature objects or materials;
- **noise and vibration hazards**;
- **radiation hazards** — both ionising and non-ionising;
- **materials and substances hazards** — such as hazards produced, used or emitted by machinery or from the construction materials;

For more information, see the Commission's guide, *Plant design: Making it safe: A guide for designers, manufacturers, importers, suppliers and installers of plant* and Resource Safety's fact sheet series on manual tasks in mining.

- **ergonomic hazards** — for example physiological or operational errors with inadequate matching of machinery and human characteristics. See Appendix 5 for more discussion on these hazards;
- **maintenance related hazards** — for example when guarding is removed or deactivated to allow for cleaning, maintenance or access to the area surrounding a machine;
- **slips, trips and falls hazards** — for example surface of floorings and means of access; and
- **work environment hazards** — for example the influence of environmental conditions such as temperature, weather or lighting.

4.3 Inherently safe design measures

Experience shows that protective measures built into the design are more likely to remain effective even where well designed safeguarding fails or is vulnerable to error or the failure to follow safe use information.

Inherently safe design measures reflect the 'hierarchy of control' principle, referred to in Section 2.3 of this code. They are a first step in the design process.

Examples where the reliance on safeguards for maintenance work might be eliminated include:

- locating the oil filters and grease nipples on the opposite side of a machine to hot parts; and
- locating lubrication points away from moving parts.

Where required, additional information on inherently safe design may be found in Australian Standard, *AS 4024.1202 Safety of machinery: Part 1202: General principles - Technical principles*.

Note the term 'safeguarding' is used here specifically to refer to technical measures such as machinery guards and safety devices.

Geometrical and physical factors

Aspects to consider could include:

- the visibility of working areas from the control position;
- shape and proximity (or gaps) between mechanical components;
- reducing sharp edges;
- enabling effective working positions and accessibility of controls; and
- limiting forces or emissions.

Technical information

Technical insight may be developed from standards, codes and calculations and address stress limitations, materials and properties, emission values, and component reliability.

Stability aspects

Design of sufficient stability may take into account factors such as:

- geometry of the base;
- weight distribution;
- dynamic forces;
- vibration;
- oscillations;
- the nature of the support surface; and
- external forces.

Maintenance

Important maintainability aspects include:

- accessibility;
- ease of handling; and
- reducing the number of tools and equipment required.

Ergonomic principles

Consideration of ergonomic principles, or the machine-operator interface, can reduce exposure to physical risks, for example amputations and physiological or mental strain, and reduce the likelihood of errors in all aspects of machinery use.

Typical ergonomic elements include:

- the nature of postures and movements;
- the ease of physical operation;
- the effects of noise or temperature;
- the lighting environment;
- the clarity and location of manual controls; and
- the design of dials, markings and displays to best fit the characteristics of human perception and cognition.

An important application of ergonomics is the use of anthropometric (human body) measurements in machinery design. This type of information is important in determining the dimensions of access openings for maintenance and repairs, the space requirements for operators, and the safety distances and gaps to prevent contact of parts of the body with danger zones.

Ergonomic design principles are discussed further in Appendix 5.

Types of energy

Energies that may be considered in this design aspect include electrical, hydraulic and pneumatic.

Design specifications should take into account:

- means of limiting energy to maximum ratings;
- controlling surges or rises;
- the effects of leakage or component failures;
- the effects of harmful external conditions; and
- deactivation for adjustment or maintenance.

Control systems

Control systems can assist in reducing the consequences of hazardous machine functioning such as unintended start up, uncontrolled speed changes or failure of protective devices.

Reliability of safety functions

This aspect of design includes consideration of:

- the reliability of all machinery components;
- use of safety failure modes of components;
- duplication or redundancy of safety related parts; and
- automatic monitoring of fault conditions.

In the case of safety related parts of control systems, the designs need to be independently validated.

Where required, additional information on reducing the likelihood of failure through good design principles, and on typical failure modes, may be found in Australian Standard, *AS 4024.1502 Safety of machinery: Part 1502: Design of safety related parts of control systems - Validation*.

4.4 Considering the life cycle during design

The 'life cycle' of the machinery or plant should be considered during the design phase, and design features introduced to control unacceptable risks that may occur at different stages in its life. This should be done by eliminating hazards at source where practicable.

The life cycle phases for machinery and plant are:

- **manufacture** — examples of controlling or eliminating hazards at source include:
 - the replacement of spoked gears with gears with a solid disc to eliminate a shear hazard; or
 - building a housing around obvious hazards rather than relying on fitting guards later;
- **transport** — for example, a machine, such as a metal lathe, that could be delivered fully assembled would be much heavier on the headstock end than the tailstock end. In this example, the designer might foresee the potential for the lathe to slip out of its lifting slings and incorporate lifting eyes to ensure the slings are located in positions that enable the lathe to be lifted horizontally;
- **installation** — to minimise hazards during installation, a large machine might be designed so that it is supplied in modules that can be placed in position by a crane. This avoids the need for installers to work at height or manually handle heavy items;
- **commissioning** — to avoid problems with inadvertent energising of various areas of machinery or plant, test points for instruments and alarms might be built into the machinery or plant;
- **use** — consideration should be given to how an operator will safely operate the machinery or plant. For example:
 - if the operator is to be seated, this could involve ergonomic considerations such as the type of seating and the ease with which controls can be reached and operated; or
 - if it is a large machine, which the operator has to move around, consideration might be given to providing a portable emergency stop button;
- **maintenance** — considerations should include providing ready access to areas identified during design requiring regular maintenance, such as cleaning, lubrication and adjustment. Other considerations for maintenance include:
 - routine adjustments should be designed to be carried out with the machine stopped but without the need for removal of safeguards or dismantling of machine components;
 - where frequent access is required, interlocked guards should be used;
 - self-lubrication or central lubrication of parts should be considered if access is difficult; and
 - positive lock-off devices should be provided to prevent unintentional restarting of machinery, particularly after a machine has shut down unintentionally;
- **storage** — considerations should include how to store a machine so that it does not present hazards in storage or when started after a period of inactivity. It might also include procedures for safe breakdown for storage; and
- **disposal** — hazards to people breaking down machines for scrap should be considered. For instance, considering hazards associated with potential energy, such as springs and pressure devices, and hazardous substances that are part of the machine or plant, for example PCBs and asbestos.

See also
Appendix 5
Ergonomics
design
principles.

4.5 Basic rules for guard design

In circumstances where intrinsic safety is not achieved through the design, machinery guarding will be required to eliminate any remaining hazards.

The primary function of a guard is to provide a physical barrier between a worker and the dangerous parts of machinery or plant. When selecting controls such as guards, careful attention to design and layout at the outset can eliminate many of the risks to safety and health and avoid later problems.

See Section 2.3 of this code and, for non-mining workplaces, regulations 4.37 and 4.29(j) of the OSH Regulations and, for mining workplaces, regulation 6.2 of the MSI Regulations.

Basic rules for guard design

Avoid second best when designing a guard.

Some of the basic rules for guard design are:

- ensuring materials used are of suitable strength and good quality;
- recognising that simply having any sort of guard may not be enough. Poorly designed or inappropriate guarding is known to contribute to injuries. Ideally, a guard should be custom-designed for the machine and the work process;
- considering carefully the environment in which the guard is used and the needs of operators and maintenance workers; and
- if a guard is used from another machine, checking carefully to ensure that it:
 - is not defective;
 - fits the target machine;
 - is of suitable strength and quality for the new application; and
 - achieves the aim of controlling the risk.

Guarding of operational and non-operational parts

When considering the need for guarding, consider operational and non-operational parts of the machine.

Start with obvious operational parts such as:

- rolls, for example calendars and flour mills;
- saws, for example circular and band saws;
- drills and drill chucks;
- cutters in metal working machines, including the blades of guillotines and the tools of power presses; and
- beaters.

Then consider non-operational parts such as:

- chains and sprockets;
- belts and pulleys;
- gears including rack and pinion sets;
- shafts, plain or threaded; and
- flywheels.

Consider other safety and health issues

In determining the most appropriate guard design for the hazard, risk and machine, other issues or risks should be considered. This is part of the holistic risk management process - see Section 2.4 of this code.

Guarding can also play a useful role in dust and noise reduction. In many cases, issues of wear, heat and ventilation affect operating efficiency and may have consequences for safety and health.

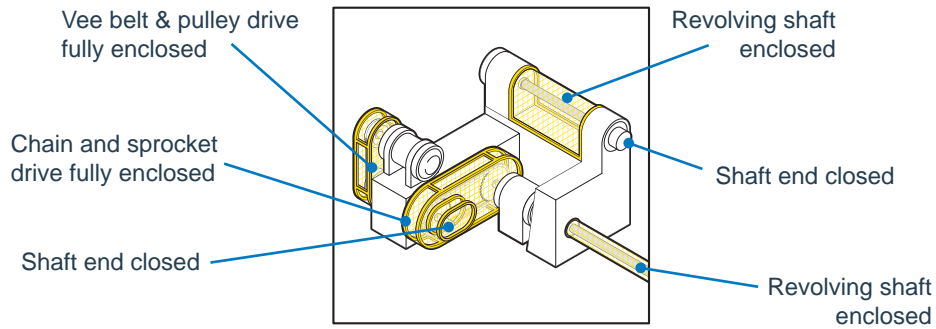

Illustration 23. Machine guards. Yellow = guarding.

Where required, additional information may be found in relevant Australian and Australia/New Zealand Standards. See Appendix 3 for more details.

Selection of material for guards

The selection of material from which guards can be constructed is determined by four main considerations. These are:

- strength and durability, for example use of non-metallic materials in corrosive environments;
- effects on machine reliability, for example a solid guard may cause the machine to overheat;
- visibility, for example there may be operational and safety reasons for needing a clear view of the danger area; and
- the control of other hazards, for example the use of a material that will not permit the ejection of molten metal.

4.6 Servicing considerations

During the design of guards, safe procedures for their removal for repair, clearing jams and breakdowns should be considered.

Servicing matters to consider include:

- following documented safe work procedures, including the manufacturers' instructions;
- proximity to hot or sharp parts;
- cool down or warm up periods;
- lock-out provisions or permission for guard removal;
- sufficient room to perform tasks without risk of injury or strain;
- stored energy in the machine or materials being processed;
- any additional hazards arising from maintenance procedures, for example testing while machine is unguarded (a 'dry run'), working at heights and use of solvents; and
- maintaining or updating service records.

5. Guards for different machines

5.1 Exposed rotating cutting machinery

Exposed rotating cutting machinery includes cut-off saws, milling machines, friction cutting and boring equipment. Hazards arise from the exposed blades and risks include cutting flesh or limbs or entanglement.

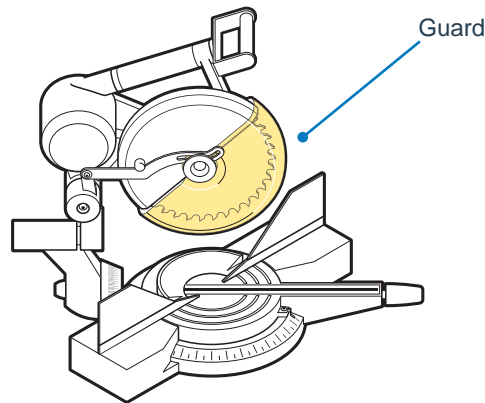

Illustration 24. Self-adjusting guard for a drop saw. Yellow = guarding.

A particular point to note is the self-actuating visor fitted to the fixed guard. If this is not fixed to the fixed guard, in a poor position or jams in the open position, then the cutter's teeth will be exposed when the machine is at the top of its stroke. As the cutter is raised or lowered, the visor should remain close to the work piece.

5.2 Pulleys and drives

Pulleys and drives are used in a range of machinery. The main hazards are nip-points and all need to be guarded so they are out of reach for operators and other people in the vicinity to prevent risks of entanglement.

Interlocked guards are preferable for pulleys and drives. In some cases, a hinged section may be appropriate to enable access during machine setting. Such control measures should be designed and installed so that a tool is required to remove and replace a guard.

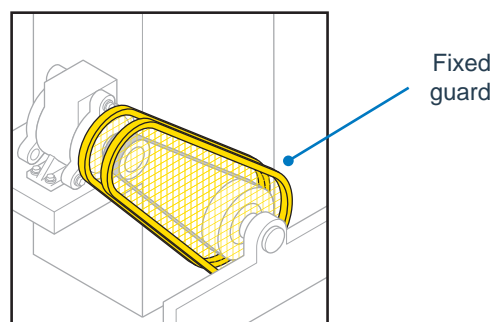

Illustration 25. Fixed guard for a pulley and drive constructed of wire mesh and angle section preventing access to transmission machinery. Yellow = guarding.

5.3 Rotating shafts and rollers

Interlocked guards are preferable for rotating shafts and rollers. Examples of rotating shafts include couplings, spindles, fan-shafts and ironing rollers.

Guards should provide protection against loose clothing and long hair getting entwined with rotating shafts. Appropriate work processes may include the requirement that operators not wear loose clothing, such as long sleeved shirts or jackets, and tie long hair back or wear a head covering.

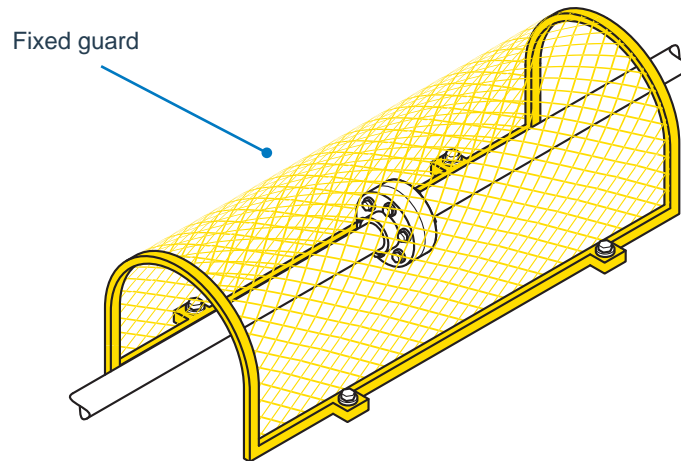

Illustration 26. Fixed guard on rotating shaft or coupling. Yellow = guarding.

5.4 Power take offs (PTOs)

The PTO is situated at the rear of a tractor and provides power to drive implements attached to the tractor. PTOs connect tractors to implements such as boom spraying equipment and feed grain roller mills. They are also found on other plant such as slashers.

The PTO shaft provides a flexible drive coupling between a tractor and an implement enabling the two to move relative to each other without disrupting the transfer of rotational power. Power is transferred via a telescopic shaft of varying shapes. The ends of the shaft are connected to the tractor and implement by universal joints.

Hazards and risks

Entanglement in PTO shafts and couplings have resulted in severe injuries, many of which have been fatal.

There does not need to be any protruding parts from the PTO assembly for entanglement to happen. Clothing only needs to wrap around onto itself once, then the friction of the contact makes it stick, and this force increases as the PTO turns.

In assessing the risks of injury from a PTO, factors to consider include whether there is:

- adequate guarding of the rotating equipment;
- adequate training of workers, including informing workers of the dangers associated with the equipment;
- a risk of entanglement due to clothing, hair, jewellery or tools; and
- whether the PTO was made and tested to an appropriate standard, such as an Australian Standard.

Control measures

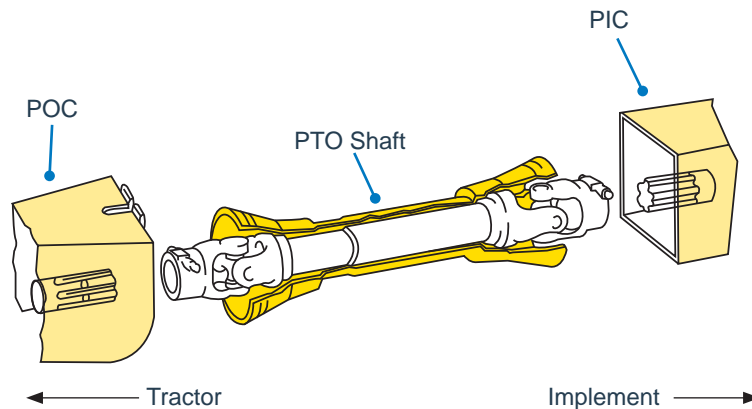

Illustration 27. Power take off guarding. Yellow = guarding.

The guarding controls for a PTO include:

- a power output coupling (POC), which is a fixed guard (also known as the 'tractor master guard') permanently attached to the tractor. It may be movable, but capable of being returned to and held securely in position when the tractor is in use;
- an implement power input coupling (PIC) guard permanently attached to the implement. It may be movable, but capable of being returned to and held securely in position when in use. There should be no 'nipping point' where body parts or clothing can be caught;
- a PTO shaft guard that extends into the tractor POC guard area and the implement PIC area for the maximum practical distance. The guard may be of a rotating or non-rotating type. A non-rotating type of guard requires a means of restraining it;
- where it is necessary to have some form of protection in the PTO drive line, torque limiters, free wheels or clutches should be located at the power input connection (machine end) of the PTO drive shaft;
- the restraining devices used to prevent rotation of the shaft guard should not be used as a means of supporting the PTO drive shaft or guard when the machine is uncoupled;
- when the machine is not in use, the drive shaft and the guard on the cradle should be supported. If there is no cradle, support the shaft and guards by other means to give equivalent protection against damage;
- ensuring all guards specified by the manufacturer are in place and well maintained;
- if a guard needs to be removed for maintenance or cleaning, ensuring plant is isolated and 'locked out' so that it cannot be run until the guarding is back in place;
- referring to the manufacturer's fitting, operating and maintenance instructions; and
- checking all guards regularly for wear and damage, for example daily when in use, and replacing damaged ones.

If required there is a specific Australian Standard for PTO guards, which gives specifications for the guards for PTO shafts, as well as the POC and PIC. All off-the-shelf guarding components should meet the specifications in the Australian Standard, *AS 1121.4 Agricultural tractor power take offs — Guards for power take-off (PTO) drive-shafts — Strength and wear tests and acceptance criteria*.

The PTO shaft may be protected by any of a number of standard PTO shaft and coupling guards. They should meet the requirements of Australian Standard, *AS 1121.4*. These items wear out, and are a consumable that need to be regularly checked and replaced when required.

Older tractors and implements

Many tractors and implements manufactured before Australian Standard, AS 1121.4 was released in 2007 do not have original POC or PIC guards, or the originals may have deteriorated. Employers still have a responsibility to ensure that all components of the PTO are adequately guarded. This may mean purchasing guards or having them manufactured. Guards should be made to the dimension and strength specifications described in the Australian Standard.

5.5 Power stamping presses

Power stamping presses are machines used for stamping various materials by the closing action of two parts, one moving (punch) and one stationary (die). The product is formed when the punch and die are brought together by force generated by a motor and flywheel.

There are two main drive systems, key clutch and hydraulic. Operation may be either by automatic feed or by manual operation, where each individual piece of material to be formed is placed into the die area by the operator. Most power press injuries occur in the manual mode of operation.

Hazards and risks

The main hazard of a power stamping press is where the punch and die come together to form the product. This creates a risk of having a part of the body crushed or cut through a crushing or shearing motion. Drive belts have in-running nip points, which present a risk of drawing in with subsequent crushing or amputation, where a pulley has sharp edges.

Control measures

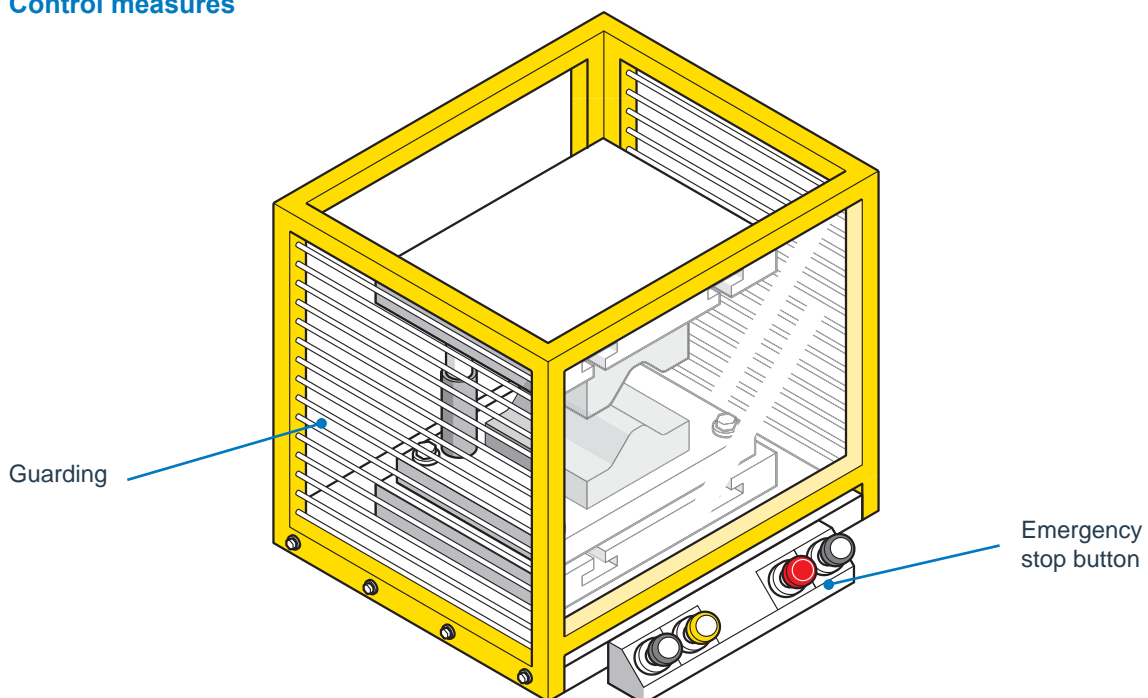

Illustration 28. Power stamping press.
Yellow = guarding. Red = emergency stop button.

Before a power stamping press is initially operated, a competent person should assess the press and process to determine the requirements for adequate guarding. This is important because power stamping presses are used for different pressing jobs and often have to be set up differently to perform the work.

The controls for power stamping presses include interlocked guards, fixed guards, presence-sensing guards, two handed controls, automatic guards, enclosed dies, automated process feeding, reduced die daylight openings and administrative controls.

A fixed guard prevents access by an operator into the hazardous area of the press but is only effective while the guard is secured in its correct position. However, a fixed guard can incorporate slides that can be adjusted with the aid of a tool to allow work to be fed through the guard into the stamping area.

With mechanical and hydraulic presses, it is necessary to fit anti-repeat devices to prevent non-initiated power strokes from occurring as a result of a malfunction within the mechanism of a press. Hydraulic presses also require double action valves to prevent the activation of equipment during a malfunction or failure of a vital component.

Presence-sensing devices (photoelectronics) detect the presence of a person, or part of them, in a defined area and prevent dangerous parts of machinery moving while anyone is in that area.

Installation of presence-sensing devices should comply with Australian Standard, *AS 4024.3 Safety of machinery: Part 3: Manufacturing and testing requirements for electro-sensitive systems — Optoelectronic devices* or Australian Standard, *AS 4024.4 Safety of machinery: Part 4: Installation and commissioning requirements for electro-sensitive systems — Pressure-sensitive devices*, as applicable.

Where required, Australian Standard, *AS 4024.3001 Safety of machinery: Part 3001: Materials forming and shearing — Mechanical power presses* and Australian Standard, *AS 4024.3002 Safety of machinery: Part 3002: Materials forming and shearing — Hydraulic power presses* contain additional information on the safeguarding, guarding design and manufacture for power stamping presses.

Maintenance

The manufacturer's instructions should be referred to in the development of maintenance and repair programs.

Maintenance and repair programs should specify:

- where servicing is required;
- the extent of servicing required;
- the nature of the servicing required;
- the frequency of servicing;
- who is responsible for maintaining repair and maintenance programs;
- how defects will be corrected; and
- performance testing and evaluation standards.

Programs should be reviewed regularly to ensure their effectiveness.

In order to keep accurate maintenance records, a recording or reporting system should be developed, implemented and maintained.

5.6 Press brakes (mechanical and hydraulic)

A press brake is a machine generally limited to linear bending and forming of material, for example sheet metal and heavy gauge material.

Hazards and risks

The main hazard of a press brake is where the punch and die come together to form the product. The impact can have a crushing, cutting or shearing motion, which creates a risk of having a part of the body crushed or cut.

Drive belts have in-running nip points, which present a risk of entanglement and abrasion. Hydraulic hoses may also pose risks if they leak or burst, including slip hazards and hydraulic fluids coming into contact with workers.

Control measures

The front dies of a press brake and its sides and rear require guarding. There are three forms of guarding for the front of the dies on a press brake, in particular a fixed guard, interlocked guard and a light or presence-sensing system.

Where workers have to hold or stabilise the material, or need frequent access to closing dies, presence-sensing devices may be required to ensure safe operation. Presence-sensing devices may be light curtains or light beams. Automatic stops should also be guarded and back-gauging equipment is recommended.

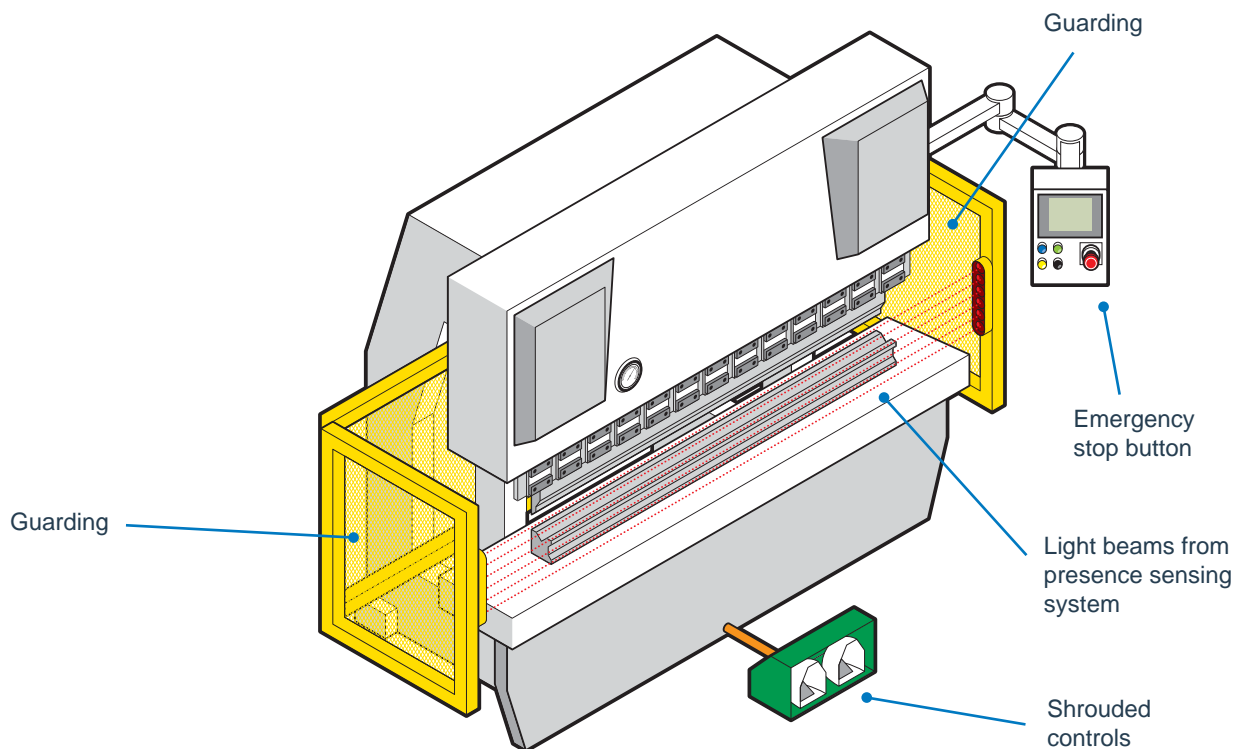

Illustration 29. Press brake.

Yellow = guarding.

Red = light beams from presence-sensing system and emergency stop button.

Green = shrouded controls

Safe system of work for press brakes

In cases where guarding of any moving parts of the plant does not eliminate risks of entanglement, or where it is not practicable to guard the parts, it must be ensured that people do not operate or pass close to the moving part unless a safe system of work is in place to reduce the risks.

Presence-sensing systems should be installed to specifications set up in Australian Standard, AS 4024.3 *Safeguarding of machinery: Part 3: Manufacturing and testing requirements for electro-sensitive systems — Optoelectronic devices* or Australian Standard, AS 4024.4 *Safeguarding of machinery: Part 4: Installation and commissioning requirements for electro-sensitive systems — Pressure-sensitive devices*, as applicable.

Presence-sensing systems must be operated and maintained according to the manufacturers' instructions.

Records must be kept on any maintenance, inspection, commissioning and alteration of a presence-sensing system, as well as any test results, while it is at the workplace. These records must be accessible at all reasonable times to workers and safety and health representatives, where they exist, at the workplace. Records such as daily log books should be kept close by, and other documents should be accessible within a reasonable amount of time.

Australian Standard, AS 4024.3001 *Safety of machinery: Part 3001: Materials forming and shearing — Mechanical power presses* and Australian Standard, 4024.3002 *Safety of machinery: Part 3002: Materials forming and shearing — Hydraulic power presses* contain additional information in relation to guarding devices and their design and manufacture and the safeguarding of press brakes.

Presence-sensing systems for press brakes: light curtains

Light curtains consist of several pairs of light box units and a control box. Each light box pair has a transmitter and receiver.

The transmitter generates a curtain of high intensity micro-second infra-red light pulses across the machine operator's work area. This curtain of light is transmitted an appropriate distance from the hazardous area, as determined by a risk assessment or in accordance with Australian Standard, AS 4024 *Safety of machinery* series. Any intrusion into this light curtain produces a signal for the control box to stop the machine.

In order to assist the operator, these light curtain systems have a variety of operating modes, which may be set according to the type of work being done. For example:

- **continuous stroking mode** — when the control pedal is depressed, the machine will move from the top of the stroke and continue to stroke while the pedal is depressed. If the light curtain is penetrated while the machine is down-stroking, the machine will stop;
- **top-to-top mode** — the machine operates as in the continuous mode, except that, regardless of whether the operator releases the foot pedal, the machine will stop at the top after one cycle;
- **bottom stop mode** — the machine starts from the top of the stroke when the pedal is depressed and stops leaving a daylight gap between the top and bottom beam, in accordance with Australian Standard, AS 4024 *Safety of machinery* series or as determined by a risk assessment. At this point the light curtain is muted or bypassed. Depressing the pedal again moves the machine to the bottom of the stroke and returns it to the top where it stops and at this point the light curtain is reactivated;
- **bottom stop-to-bottom stop mode** — this is similar to the bottom stop mode except the machine does not stop at the top of the stroke. It stops at the 6 mm gap mute position or when the light curtain is obstructed on the down stroke;
- **pulsing mode** — the light curtain is muted or bypassed and the machine can be moved down in 10 mm increments with each depression of the pedal. This mode allows the operator to stand inside the curtain for close work; and
- **link mode** — this is used for mechanical presses and is similar to the bottom-stop mode, except the initial down stroke is controlled by an electric foot-switch and, at the 6 mm mute point, the pedal controlling the mechanical friction clutch is operated to finalise the stroke of the machine.

Presence-sensing systems for press brakes: light beams

In this type of guarding system, a front beam protects the operator, while allowing work to be performed close to the blade. The centre beam sets the mute bypass point. The rear beam protects people at the rear of the machine, eliminating the need for mechanical guarding.

For non-mining workplaces, see regulations 4.34(1) and (3) of the OSH Regulations and, for mining workplaces, see regulations 6.25(1) and (3) of the MSI Regulations.

Removal of or turning off a guard

On occasions it may not be possible to perform work with the guarding system in place. Removal of or turning off a guard should only occur if the guard makes it impracticable to perform close work and a risk assessment is carried out by a competent person.

When a guard is removed or a guarding system turned off:

- it must be ensured that workers do not operate or pass close to a moving part unless a safe system of work is in place;
- there is still a requirement under the law to install suitable guarding to protect operators from hazards at the rear and sides of the machine; and
- there should be an indication that the system is muted, for example with a light.

If the work to be performed requires guarding to be removed on a regular basis, the machine may not be suitable for the application. Measures should therefore be taken to use another machine or to modify the existing machine so the guard does not have to be removed.

Additionally, the safe system of work should be documented and the operation supervised by a competent person.

For non-mining workplaces, see regulation 4.37(1)(i) of the OSH Regulations and, for mining workplaces, see regulation 6.27 of the MSI Regulations.

5.7 Conveyors (bulk handling)

Conveyors are a means of transporting materials from one point to another. Types include belt conveyors, screw conveyors and bucket conveyors.

Hazards and risks

The main hazards of a conveyor are the numerous in-running nip points, which present a risk of entanglement, crushing and abrasion. The drive system itself may also pose risks of entanglement or abrasion.

Control measures

Fixed guards, which enclose in-running nip points and the drive mechanism, are often the most effective ways of safeguarding conveyors.

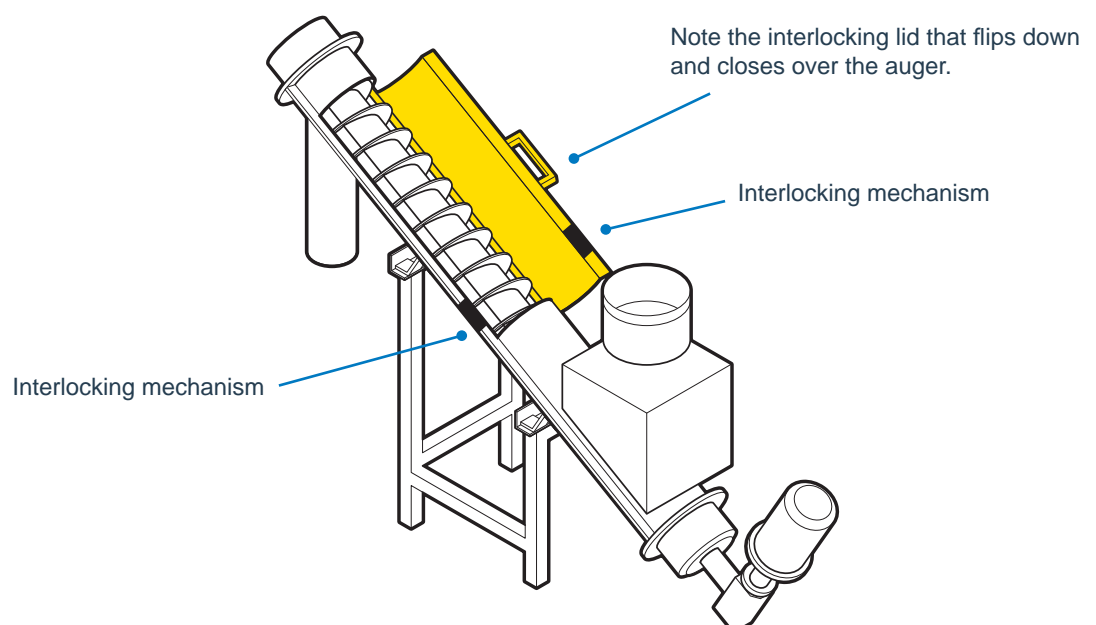

Illustration 30. Typical guard for head and tail section of a conveyor. It is important to note that physical guarding is not the only method available for guarding conveyor systems. Yellow = interlocking guarding.

Large conveyors, such as stockpilers, generally require guarding of both carry idlers and return idlers where under high tension and accessible. This should be done according to Australian Standard, *AS 1755 Conveyors — Safety requirements*.

Other controls include:

- **electrical isolation (lock-out and tag-out)** — although safeguards are provided, which prevent access during most phases of machinery or plant life, they may not be effective at all times because of the need to access hazardous areas such as during maintenance and set-up. There are set requirements under the OSH Regulations and MSI Regulations for isolation. See Section 6.3 of this code;
- **start and stop controls** — conveyors should be provided with appropriate drive power isolation, whether electrical, hydraulic, pneumatic or mechanical. Isolation should be secured by means of a lock-out and tag-out system. At each conveyor start location, a clearly labeled 'stop' control should be provided. Where the start control is in a position from which the whole of the conveyor operation cannot be viewed, a visible or audible signal should be provided to warn people in the vicinity;
- **emergency stop controls** — a lanyard type pull-wire emergency stop is the most suitable emergency stop for exposed belt type conveyors, where workers are required to access the belt area when the conveyor is in use, for example when placing and removing parcels at a transport depot. The lanyard type allows access to the emergency stopping facility from all of the points where a person may be working during the conveyor's use. Emergency stop controls should be manually reset before the conveyor can be restarted from its normal start control;
- **access provisions** — machinery design should allow all routine adjustment, lubrication and maintenance to be carried out without removing guards or extensive dismantling of components. Lubrication and routine maintenance facilities should be incorporated outside the danger area wherever practical. However, when people require access to the danger area, for example for machine setting, safe isolation procedures should be used;
- **lighting** — provide local lighting on the machine for the work area when the machine or guards make normal lighting inadequate for safe operation. Local lighting should also be provided in regular maintenance areas that are poorly lit, for example inside certain electrical compartments where electrical isolation is necessary for access; and
- **training** — adequate training must be provided for people working around conveyors.

More information

Where required, Australian Standard, *AS 1755 Conveyors — Safety requirements* provides more information in relation to minimum safety requirements for the design, installation and guarding of conveyors and conveyor systems and training.

Australia New Zealand Standard, *AS/NZS 1680.1 Interior and workplace lighting — General principles and recommendations* provides more information, where required, in relation to the general principles and recommendations for lighting.

5.8 Robotics

Robots are often used to remove the more traditional hazards associated with machinery and perform some high-risk operations, for example in the biotechnology field.

A common misconception is that robotic operations are 'safe' because there is little or no worker interaction. However, safety and health issues with robotics can arise during operation due to errors, ejection of materials, trapping points, failures and malfunctions. They may also arise in relation to installation, repair and maintenance. There may also be biological, chemical or environmental hazards.

While operation may be safe, a risk assessment should be undertaken to ensure workers' safety during all phases of the machinery's life and use. The risk management process should be followed, with reference to the manufacturer's instructions, during installation (commissioning), testing and start up, repair and maintenance.

Hazards and risks

Robots have inherent dangers, including unpredictable action patterns, high speed operations, ability to move in free space and ability to be reprogrammed or reconfigured to change their use and application.

Some of the hazards associated with industrial robot operation include:

- **impact** — robots may move in a direction not anticipated or planned at high speed in linear or rotary directions. The robot may also eject work-pieces, off cuts or molten metal. Workers are at risk from being hit by the robot or parts of the work;
- **trapping points** — these may be created by movements of the robot or associated equipment such as work carriages, pallets or transfer mechanisms. On the robot itself, trapping points may be identified on the arm of the robot, between the arm and the column, and between the arm and fixed objects. Workers may be crushed or become entangled by the robot or the process, including being crushed between a rapidly rotating robot arm and barriers close by;
- **control errors** — these result from intrinsic faults within the control system of the robot, for example software, electrical interference, program corruption and sub-controls associated with the electrics, hydraulics and pneumatics;
- **human error** — these could occur during programming, teaching, maintenance and repair. Or they may occur in work handling close to the robot or at loading or unloading stations;
- **failure or malfunction** — these may occur with the electrics, hydraulics and pneumatics;
- **biological or chemical hazards** — these may occur where robots are being used to reduce the risks from hazardous or infectious processes. Workers may risk inhaling or absorbing hazardous substances. In this case, particular attention should be paid to the process itself and to any breakdown or emergency procedures that may be required in case of spillage, contamination or breach of the system; and
- **environmental hazards** — these include dust vapours, fumes, lasers, radiations and flammable and explosive atmospheres. Workers may risk injuries or harm, for example burns and inhaling or absorbing hazardous substances.

Control measures

Hazards associated with moving parts, other than at point of operation, should be eliminated by design. If not, protection must be provided against them.

Industrial robotic installations may be safeguarded by one or more guarding and presence-sensing devices. Enclosure is a frequent control measure for robotic systems, as well as restricting access and ensuring the machine is turned off in the vicinity of people.

Fixed or distance guards may be practicable where the guard will not interfere with the mechanism of the robot. It should be necessary to use tools to remove the guards in order to gain access to the restricted danger area. Guards or fences should be located to prevent people from reaching into a restricted area. Any openings provided for feeding material into the process should be designed to prevent access to a hazard by any part of a person.

Interlocked guards initiate an emergency stop when opened. While such a guard should prevent initiation of automatic operation, it may maintain power for other functions. Return to automatic operation would therefore require both the closing of the interlocked guard and activation of a start procedure.

Presence-sensing devices should be designed and positioned to detect entry into a restricted space or danger area and cause the automatic operation of the robot to cease when entry is detected. The failure of this device would also cause the robot to cease operation.

Photoelectric systems consist of a combination of a photoelectric device, for example a light curtain or beam, robot control system, drive and brake units and, where appropriate, an overall performance monitor. Interruption of the light curtain will cause the operation of the robot to cease. Therefore it should not be possible to stand or place a body part between the light curtain and the hazardous part of the process. Photoelectric devices can be set to control the size of any penetration, for example a hand but not the arm or an arm but not the body.

Pressure sensitive mats operate by means of a number of suitably spaced electrical or fluid switches or valves contained within a mat covering the approaches to a restricted space. Pressure on the mat will cause the automatic operation of the machine to cease. Such a guard should be designed so it is not possible to circumvent or overstep a pressure sensitive mat into a restricted area.

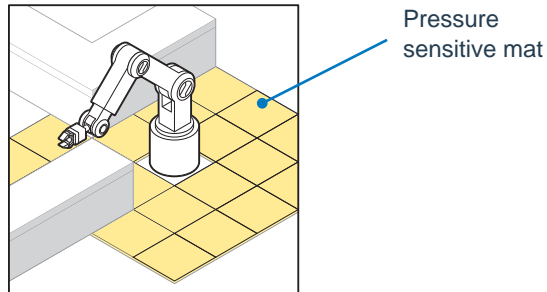

Illustration 31. Pressure sensitive mat.

Presence-sensing safeguard systems must be operated and maintained according to the manufacturers' instructions. Records must be kept on any maintenance, inspection, commissioning and alteration to a presence-sensing system, as well as any test results, while it is at the workplace. These records must be accessible at all reasonable times to workers and safety and health representatives at the workplace.

Additional control measures

The highly technical and programmable nature of robots means that additional safeguards should be considered as well as the guarding of dangerous moving parts.

Measures should be taken to prevent unauthorised access to controls and protect the robot system from unintended operation. Attention should also be paid to controlling hazards in adjacent areas, for example loading or unloading stations and associated equipment. In particular, removal of associated equipment, such as conveyors, transfer systems and trolleys, should not allow access to restricted areas. If so, these points should be safeguarded.

Control systems

Actuating (start) and control systems for robotics are usually of the programmable electronic type. These should be protected against unauthorised access, for example by location in a lockable control cabinet or room. Controls should be constructed or located to prevent unintentional operation. This can be achieved by shrouding, guarding, gating, appropriate positioning or otherwise designing to prevent accidental operation.

Master switches

Master switches should be provided to isolate all motive power from the robot and may be the same device as an emergency stop device. This master switch should be capable of being locked in the isolating position and require manual resetting.

Training

Appropriate training is essential when controlling the risks associated with industrial robot machines. Inadequate training may increase risks at most stages of robot operation.

Safe work systems

Safe work systems are required to minimise some of the risks associated with robotics. A safe work system involves recording procedures for entry, including who is permitted access and to perform identified tasks, maintenance and repair. Inspection and maintenance activities may provide a different set of hazards to performance or monitoring of work and should also be assessed in terms of risks.

Where required, Australian Standard, *AS 4024.3301 Safety of machinery: Part 3301: Robots for industrial environments — Safety requirements* contains more guidance in relation to the requirements of the design, construction, safeguarding and installation of industrial robots.

For non-mining workplaces, see regulation 4.34(1) and (3) of the OSH Regulations and, for mining workplaces, see regulations 6.25(1) and 6.25(3) of the MSI Regulations.

6. Other machinery safety issues

6.1 Work organisation

For machine guarding to work effectively, the movement of materials on site and the job procedures related to the machinery must be thoroughly understood. Safe machinery operating procedures or instructions for machinery must be developed, and workers must be adequately trained to ensure safe work practices are maintained.

New risks should not be introduced into the workplace as a consequence of the introduction of new technology, machinery or plant, or modifications to existing machinery or plant. At these times, risk assessments must be performed. These should be carried out in consultation with workers.

6.1.1 Layout

Machine guarding will be more effective if it is used in conjunction with proper attention to layout. Machines that are poorly located or too close together may not be safe even if guarded.

Some basic points to consider in relation to layout are to:

- avoid congestions or worker movements near machinery that are likely to increase the risk of injury;
- eliminate or minimise hazardous movements in relation to operation, cleaning or maintenance, for example blockages;
- where waste materials are generated, include space for storage or accumulation until cleared. They should not be allowed to clutter walkways or work areas;
- consider 'traffic flow' by identifying the movements of trucks, materials and people. By defining simple, well marked and well understood traffic areas and directions, the likelihood of people coming near dangerous machinery, and therefore the risk of injury, can be reduced; and
- review proximity of moving parts near other machinery or plant and fixtures in buildings.

6.1.2 Housekeeping

Untidiness can cause slips, trips and falls. Injuries can be avoided by:

- keeping work areas, walkways and other access paths clear and clean. They should be clearly marked; and
- preventing spills, which may cause slips. Design machinery and work processes to minimise lubrication oil loss or spillage. Clean up spills as soon as possible and avoid any oily residues on the floor. Provide a rough anti-slip floor where this is not practical.

6.2 Safe work procedures

Employers must ensure there are safe systems of work and safe working procedures in relation to machinery and plant. These should address issues such as:

- the guarding on items and the need for it;
- instructions on procedure to operate plant when guards are removed;
- instructions on not removing the guarding. Systems should be in place to prevent workers from bypassing guarding mechanisms;
- instructions on safe access to and egress from machinery and plant;
- instructions on who may use an item of plant, for example only authorised workers;
- instructions on isolation and emergency stop devices (see the next section);
- instructions for inspections, cleaning, repair, maintenance and problems that may occur; and
- emergency procedures.

See also Part 3 of the OSH Regulations for requirements in relation to provision of water, air temperature and personal protective clothing and equipment.

When new machinery and plant are introduced into the workplace:

- safe work procedures and training must be provided where there are different operating requirements, for example when the controls on a new machine are in a different place to where operators are used to; and
- any documented work procedures and manuals should also be updated.

Adequate supervision must be provided to ensure safe work procedures are followed.

6.3 Isolation

When access to machinery or plant is required for inspections, repairs, maintenance, alterations and cleaning or the plant is to be withdrawn for assessment or repair, there are general and specific requirements for employers and their 'authorised person' for the isolation of the machinery or plant from energy sources and general safety.

The employer, main contractor or self-employed person must ensure that there is a safe system of isolating the energy sources for all machinery and plant.

As part of establishing a safe system of isolation, it must be ensured that:

- there are procedures for preparing a machine for the application of isolation devices, locks and tags as practicable — see the box below;
- workers are adequately instructed and trained in the system and can demonstrate that they are competent to carry out the isolation or lock out and tag out procedures; and
- adequate supervision is provided to ensure that the isolation procedures, including those outlined below, are followed.

Workers trained in the safe system of isolation for machinery and plant must ensure that it is followed at all times.

See also the Commission's *Guidance note: Isolation of plant.*

For non-mining workplaces, see regulation 4.37A of the OSH Regulations. For mining workplaces, see regulation 6.27 of the MSI Regulations.

Isolation procedures

For non-mining workplaces, see regulation 4.37A(2) of the OSH Regulations. For mining workplaces, see regulation 6.2, 6.21 and 6.27 of the MSI Regulations.

There must be a procedure for the isolation of each piece of machinery or plant, including the application of isolation devices, locks and tags, as practicable. While a specific procedure for a machine may differ because of different situations, the following steps must be included in the isolation procedure.

When carrying out checks, tests, inspections, maintenance, alteration or cleaning or when the plant is to be withdrawn from use because of an immediate risk, the employer, main contractor, self-employed person or person having control of the workplace or its access must:

- ensure that all the hazards associated with all energy sources of the plant are identified. This may involve a comprehensive examination of the equipment's operational safety manual or consulting competent people such as engineers; and
- authorise a person ('the authorised person') to carry out the matters outlined below.

The authorised person must, if it is practicable to do so, stop the plant and ensure any risks associated with any identified hazards are reduced as far as practicable. This should include notifying any workers who may be affected by the planned isolation that it is about to occur. The authorised person must then, if it is practicable, ensure:

- a) all energy sources are de-energised and isolated using an isolation device and locked out using a lock-out device. This step should include activating all energy isolating devices and ensuring all switches and valves are in the off or safe position as part of measures to stop any attempts to activate the machine. It may include release or restraint of stored energy including, for example, completing the cycle of a flywheel, releasing steam and bleeding valves;
- b) an out-of-service tag is fixed to the plant and danger tags are fixed at the energy sources and the operating controls of the plant;
- c) the measures taken to de-energise and isolate the energy sources are tested to ensure the plant cannot be energised inadvertently;
- d) any inspection, repair, maintenance, alterations or cleaning of plant or withdrawal of it is not carried out before the above tests are carried out; and
- e) after the above work is carried out, the plant is returned to operational status. The worker who isolated the machinery should remove the lockout equipment. A procedure should be in place for cases where this is not possible, for example where work is conducted over a number of shifts or the worker has gone home sick.

If it is not practicable to carry out all of the matters in (a)-(d), then:

- the authorised person must ensure that those matters that are practicable are carried out; and
- the person who gave the authorised person authorisation must ensure that:
 - written procedures are developed by a competent person to deal with the hazards and energy sources that it has not been practicable to deal with under (a)-(d);
 - the written procedures are provided to the authorised person; and
 - the written procedures are followed by the person who is carrying out the inspection, repair, maintenance, alteration and cleaning of plant or withdrawing of it from use.

If access to plant is required for inspection, repair, maintenance, alteration or cleaning or to withdraw it because of an immediate risk to safety and health and it is not practicable to stop it, the employer, main contractor, self-employed person or person having control of the workplace or its access must ensure that:

- the plant is fitted with operating controls that allow controlled movement of the plant;
- there are written procedures to be followed in relation to anything carried out for inspections, repairs, maintenance, alteration and cleaning of plant that are designed to prevent injury to people working on it or when it is withdrawn from use; and
- people working on the plant carry out the work in accordance with the written procedures.

For non-mining workplaces, see regulation 4.37(3) and (4) of the OSH Regulations. For mining workplaces, see regulations 6.2, 6.21 and 6.27 to 6.30 of the MSI Regulations.

For non-mining workplaces, see regulation 4.37A(5) of the OSH Regulations. For mining workplaces, see regulation 6.2, 6.21 and 6.27 of the MSI Regulations.

For non-mining workplaces, see regulation 4.37A(6) of the OSH Regulations. For mining workplaces, see regulation 6.2, 6.21 and 6.27 of the MSI Regulations.

Isolation devices must be reliable and clear. The method used to isolate plant will vary depending on the type of equipment. Chains, clasps and locks are examples of devices that can be used to isolate plant. For example, steel pins and metal support bars can be used to support vehicle hoists. These devices must be locked in place to ensure they cannot be removed by others when workers are working under them.

Machines may contain stored energy, for example in springs, closed hydraulic or pneumatic circuits, suspended components or materials or torque in shafts. There must be a method or procedure to release or contain this energy as part of the lockout procedure.

Each lock should:

- be strong enough to withstand physical abuse, either intentional or unintentional;
- be made of material suitable for the environment;
- be heavy duty or specifically designed; and
- have only one key and one owner who is responsible for it to prevent its removal without their knowledge.

Master or spare keys should be kept in a designated location, away from the immediate workplace, and under the control of an authorised person. There should be strict procedures to ensure they are only used in an emergency and after thorough safety checks have been made.

6.4 Emergency stop devices

Emergency stop devices should not be the only method of controlling hazards. They should be used only as a backup to other control measures.

When choosing an emergency stop device, it is important to conduct a risk assessment to consider if:

- part of the machine may still need to operate, for example in an emergency situation;
- other safety features may still need to operate, for example pressure release valves; and
- any additional hazards may be introduced.

A risk assessment will assist in determining the level of integrity of associated circuitry. Where additional information is required see Australian Standard, *AS 4024.1501 Safety of machinery: Part 1501: Design of safety related parts of control systems — General principles for design*.

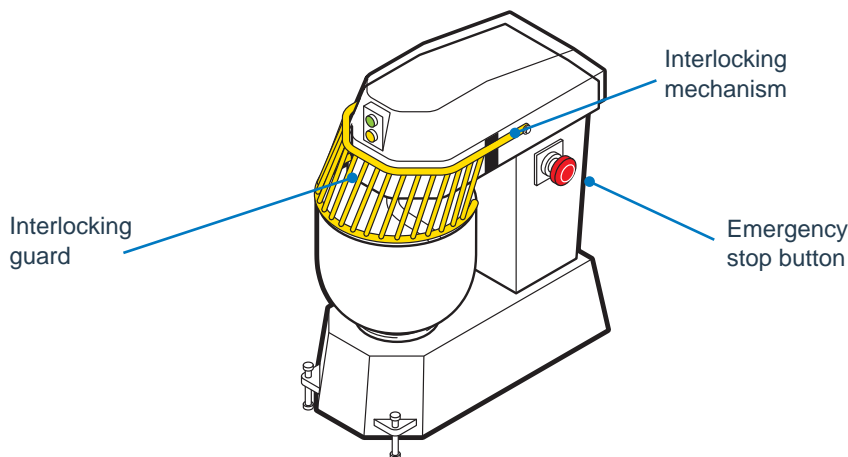

Illustration 32. Food mixer with emergency stop button.
Yellow = interlocked guarding. Red = emergency stop button.

For non-mining workplaces, see regulation 4.29(m) of the OSH Regulations. For mining workplaces, see regulation 6.2(2)(j) of the MSI Regulations.

Emergency stop devices

Ensure emergency stop devices are:

- prominent, clearly and durably marked and immediately accessible to each operator of the plant;
- have handles, bars or push buttons that are coloured red. Labelling can also be used. Consider installing ones that protrude and are not level with the surrounds; and
- not affected by electrical or electronic circuit malfunction.

Other considerations include:

- the best access for workers;
- the environment the machine is used in, for example whether there could be exposure to dust, chemicals, extremes of temperature or vibration;
- the number of emergency stop devices required. If the machine or plant is large, several devices or pull wires may be necessary;
- a manual procedure for resetting an emergency stop device. They should not be affected by electrical or electronic circuit malfunction; and
- testing at regular intervals to ensure they have not ceased functioning.

Poorly located emergency stop devices may delay shutdown in an emergency and encourage dangerous practices, such as:

- reaching across moving parts;
- a failure to shut down machinery or plant when a problem occurs; or
- situations where the machine or plant can be started by one worker while another is in a dangerous location, for example cleaning a bin.

When there are multiple devices, safe operating practices should be adopted so that machinery or plant is not restarted when it is undergoing maintenance or other temporary operations. A lock-out and tag-out system, as outlined above, is therefore an essential part of isolating an energy source to prevent accidental plant start up.

6.5 Controls and buttons

Where possible, manual control devices should:

- be designed and located according to ergonomic design principles — see Appendix 5;
- have a stop control device near each start control device;
- be located out of danger zones except where there is a necessary requirement, for example an emergency stop;
- be marked to indicate their nature and function;
- be located with the operator's control position so the operator is able to see the working area or hazard zone;
- not be able to be accidentally started; and
- where there is more than one control to start a high risk part of the plant, be arranged so that only one control can work at a time.

6.6 Inspection, cleaning, repair, maintenance and emergency procedures

To safeguard operators and other workers during inspections, cleaning, repairing, maintenance and emergencies:

- apply isolation procedures whenever maintenance or repair requires people to enter the danger area around machinery — see also Section 6.3 of this code;
- cleaning, repair, maintenance and emergency procedures should be in place and understood by workers;
- a regular inspection regime should be in place to identify any problems with machinery or plant and safeguards;
- any additional hazards associated with inspections, cleaning, repair, maintenance and emergencies should be identified and assessed as part of the risk management process; and
- special precautions need to be taken where workers are obscured while undertaking tasks, or where there are multiple operating switches.

6.7 Weight

Large machinery or plant may require extensive guarding and these guards may need to be removed for maintenance access. While some sections may remain fixed, it is preferable that the guarding be divided into easily removable sections. Sections should be designed to be removed and handled easily by one person.

Appropriate placement of handles on movable sections will facilitate ease of removal, lifting and handling and reduce the risk of manual handling injuries.

Where practicable, mechanical devices, such as cranes or other lifting devices, should be used to avoid manually moving heavy guards.

6.8 Movable guards

Guards that move out of the way for each operation (automatic guards) require special consideration.

Assess potential risks in the interactions:

- between **guard** and **machine**;
- between **guard** and **person**; and
- between **guard** and **work piece**.

6.9 Colour coding

It is good practice for all safety guards to be painted the same colour. For example:

- use high visibility yellow, provided it is different to the machine's colour, so that it can be clearly seen when a guard has been removed or when it is not in its proper place; and
- paint the surfaces behind the guard a contrasting or preferably bright colour, for example blue or red, so that when the guard has been removed, the exposed colour is clearly visible. It is then easy to identify that the guard has been removed and workers are alerted to possible danger.

Appendix 1 Relevant sections of acts and regulations

Occupational Safety and Health Act 1984

Occupational Safety and Health Regulations 1996

- Part 3 Workplace safety requirements
- Part 4 Plant
- Part 5 Hazardous substances

Mines Safety and Inspection Act 1994

Mines Safety and Inspection Regulations 1995

- Part 4 General safety requirements

The *Occupational Safety and Health Act 1984* and *Mines Safety and Inspection Act 1994* and regulations can be accessed free of charge from the State Law Publisher's website at www.slp.wa.gov.au or purchased by telephoning (08) 9426 0000.

Appendix 2 Other sources of information

Codes of practice, guidance material and other documents

Australian Building Codes Board

The Building Code of Australia. Refer to the internet site at www.abcb.gov.au

Safe Work Australia Safety and Compensation Council

Hazardous Substances Information System, available at www.safeworkaustralia.gov.au

Commission for Occupational Safety and Health

Code of practice: Managing noise at workplaces

Code of practice: Manual handling

Code of practice: Working alone

Codes of practice: First aid facilities and services; Workplace amenities and facilities; Personal protective clothing and equipment

Violence, aggression and bullying at work: Code of practice for prevention and management

Guidance note: Alcohol and other drugs at the workplace

Guidance note: Consultation at the workplace

Guidance note: General duty of care in Western Australian workplaces

Guidance note: Preparing for emergency evacuations at the workplace

Guidance note: Provision of information on hazardous substances: Material Safety Data Sheets (MSDS)

A list of codes of practice and other guidance material published by the Commission is available at www.worksafe.wa.gov.au or by contacting WorkSafe on 1300 307 877.

Department of Mines and Petroleum, Resources Safety Division

General duty of care in Western Australian mines — Guideline

Noise control in mines — Guideline

Safety and health risk management: Guideline

Underground ventilation (metalliferous mines) — Guideline

Manual tasks in mining — fact sheets 4, 5 and 9

Guidance material published by Resources Safety is available at www.dmp.wa.gov.au/resourcessafety or by contacting Resources Safety on 08 9358 8154.

Contacts for further information

Chamber of Commerce and Industry Western Australia

180 Hay Street
EAST PERTH WA 6004
Tel.: (08) 9365 7415
Fax: (08) 9365 7550
Email: osh@cciwa.com
Internet site: www.cciwa.com

Chamber of Minerals and Energy of Western Australia

Level 7, 12 St Georges Terrace
PERTH WA 6000
Tel.: (09) 9325 2955
Fax: (08) 9221 3701
Email: chamber@cmewa.com
Internet site: www.cmewa.com

Department of Commerce WorkSafe Division

Level 5, 1260 Hay Street
WEST PERTH WA 6005
Tel.: 1300 307 877
Fax: (08) 9321 8973
Email: safety@commerce.wa.gov.au
Internet site: www.worksafe.wa.gov.au

Department of Mines and Petroleum Resources Safety

Level 1, 303 Sevenoaks Street (cnr Grose Avenue)
CANNINGTON WA 6107
Postal address: 100 Plain Street,
EAST PERTH WA 6004
Tel.: (08) 9358 8002
Fax: (08) 9358 8000
Email: ResourcesSafety@dmp.wa.gov.au
Internet site: www.dmp.wa.gov.au/ResourcesSafety

Unions WA

Level 4, 445 Hay Street
PERTH WA 6000
Tel.: (08) 9328 7877
Fax: (08) 9328 8132
Email: unionsyes@unionswa.com.au
Internet site: www.unionswa.com.au

Consulting engineers

A number of consultants offer advice on safeguarding machinery or plant. If you decide to hire one, make sure they understand Western Australian legislative requirements and take an approach to the problem consistent with the principles in this code. Ask for evidence of previous work in the area and check it. If possible, talk with other employers about how they approached safeguarding of their machinery or plant. Small employers could pool with others to hire a consultant and spread costs.

Appendix 3 Australian and Australian New Zealand standards

Australian and Australian New Zealand standards are accepted standards for safeguarding machinery and plant. They are developed and published by Standards Australia and available from SAI Global Limited.

Some of the useful standards relating to machine safeguarding are listed below. These standards are current at the time of printing. Check to ensure they are still current.

Contact details for SAI Global Limited are at the website: infostore.saiglobal.com, or by telephoning 131 242.

Title	Description
<i>AS 4024 Safety of machinery series</i>	This series sets out general principles for machine guarding and identifying hazards and risks arising from the use of machinery during all phases of machine life. Methods for eliminating or reducing risks, safeguarding machines and safe work practices are described. Guidelines for assessing safety measures needed in particular circumstances are provided. They mostly do not provide guidance for safeguarding a particular type of machine. Specific types may be covered by separate standards.
<i>AS 4024.3001 Safety of machinery: Part 3001: Materials forming and shearing — Mechanical power presses</i>	This standard specifies technical safety requirements and measures for the design, manufacture and supply of mechanical presses intended to work cold metal or material partly of cold metal.
<i>AS 4024.3002 Safety of machinery: Part 3002: Materials forming and shearing — Hydraulic power presses</i>	This standard specifies technical safety requirements and measures for hydraulic presses intended to work cold metal or material partly of cold metal.
<i>AS 1121.4 Agricultural tractor power take-offs: Part 4: Guards for power take-off (PTO) drive-shafts — Strength and wear tests and acceptance criteria</i>	This standard specifies laboratory tests to determine the strength and wear resistance of guards for power take-offs, drive shafts on tractors and machinery used in agriculture and forestry and their acceptance criteria.
<i>AS 1755 Conveyors — Safety requirements</i>	This standard specifies minimum safety requirements for the design, construction, installation and guarding of conveyors and conveyor systems, both above ground and underground. It does not apply to platform elevators, moving stairways or conveyors specifically designed for the conveyance of people. It provides recommendations for inspection, maintenance, marking and identification and the training of operators.
<i>AS 2939 Industrial robot systems — Safe design and usage</i>	This standard specifies requirements for the design, construction, safeguarding and installation of industrial robot systems. Requirements for training and recommendations for the safe programming, maintenance and operation of industrial robots are included. The standard is extensively illustrated.

Appendix 4 Glossary of terms

Competent person/people — in relation to the doing of anything, means people who have acquired, through training, qualification or experience or a combination of those things, the knowledge and skills required to do that thing competently.

Consequence — this is the outcome of an event or situation expressed qualitatively or quantitatively, being a loss, injury, disadvantage or gain.

Crushing hazards — see Section 2.1 of this code.

Cutting hazards — see Section 2.1 of this code.

Danger — this is a state or condition in which personal injury is reasonably foreseeable.

Danger point — any position on a machine where there is a possibility of a person coming in contact with a moving part.

Danger zone — any area where there is a possibility of a person coming in contact with moving machinery.

Drawing-in or trapping hazards — see Section 2.1 of this code.

Entanglement hazards — see Section 2.1 of this code.

Fixed guards — see definition of 'physical barrier securely fixed in position (fixed guards)' in Section 3.1.3 of this code.

Guard — for an outline of the range of guards, see Section 3 of this code.

Hazard — in relation to a person, means anything that may result in an injury to the person or harm to their health.

Impact hazards — see Section 2.1 of this code.

Interlocked guard — see definition of 'interlocked physical barriers (interlocked guards)' in Section 3.1.2 of this code.

Isolation procedure — see explanation in Section 6.3 of this code.

Nip points — see 'Drawing—in or trapping hazards' in Section 2.1 of this code.

Plant — includes any machinery, equipment, appliance, implement, or tool and any component or fitting of it or accessory to it.

Practicable — some regulations relevant to guarding refer to something being done 'as far as practicable'. Under the occupational safety and health legislation, 'practicable' has a particular meaning and the definition can be found in Section 3(1) of the OSH Act and Section 4(1) of the MSI Act. If something is practicable, it is 'reasonably practicable', taking into account:

- the severity of any injury or harm to health that may occur;
- the degree of risk (or likelihood) of that injury or harm occurring;
- how much is known about the risk of injury or harm, and the ways of reducing, eliminating or controlling the risk; and
- the availability, suitability and cost of the safeguards.

In other words, to be practicable, something must not only be capable of being done, it must also be reasonable in light of the factors mentioned above. The risk and severity of injury must be weighed up against the overall cost and feasibility of the safeguards needed to remove the risk. Only those factors listed above are relevant, and a factor cannot be ignored unless, after considering what a reasonable person at the time would have known, the factor is clearly irrelevant. Each factor is considered in light of what a reasonable person, in the position of the person who owes the duty, would have known.

Presence-sensing guard — see definition of 'presence—sensing systems' in Section 3.1.5 of this code.

Risk — in relation to injury or harm, means the probability of that injury or harm occurring.

Risk assessment — this is the second step in the risk management process. See the explanation in Section 2.2 of this code.

Risk priority — this is the level of importance placed on a risk, where the higher the risk score, the higher the priority of controlling the risk.

Safeguarding — this is a means of preventing people from coming in contact with any hazardous parts of a machine.

Safety device — this is a device, including a presence—sensing one, other than a guard, that eliminates or reduces danger.

Shearing hazards — see Section 2.1 of this code.

Stabbing and puncturing hazards — see Section 2.1 of this code.

Appendix 5 Ergonomics design principles

See Section 2.3 of this code for the basic requirements that must be met for the safeguarding of machinery and plant. This appendix is presented as a guide on the more technical aspects of the design and development of guards, where the information is required.

When an item of machinery or plant is designed and manufactured, the people involved in the design and manufacturing processes apply knowledge and design principles concerning the characteristics and behaviours of metals and other materials used to manufacture the item.

Applying ergonomic design principles when designing machinery or plant is concerned with the application of knowledge concerning human factors, such as variability, capabilities and behaviour, to design. Ergonomics is sometimes referred to as 'human factors' or 'human factors engineering'.

Application of ergonomics design principles when designing guarding for machinery is outlined below. Where required, more detailed information can be found in Australian Standard, *AS 4024.1401 Safety of machinery: Part 1401: Ergonomic principles — Design principles — Terminology and general principles*.

1. Human variability

People vary considerably in shape and size. For example, amongst a group of 20 males aged 14 and above, there could be a:

- 375 mm difference in heights; and
- 180 mm difference in arm lengths.

Data on various body dimensions, called 'anthropometric data', is used for determining a machinery or equipment's operating heights, separation distances and the design of controls and guards. Dimensions are usually expressed in percentiles. These refer to the percentage of the population that possesses the characteristic at the measured level or lower. So a person who is taller than one percent of the population is at the 1st percentile for height. A person who is average height is at the 50th percentile for height. A person who is taller than 95 percent of the population is at the 95th percentile for height.

More detailed information can be found in Australian Standard, *AS 4024.1703-2006 Safety of machinery: Part 1703: Principles for determining the dimensions required for access openings* and Australian Standard, *AS 4024.1704-2006 Safety of machinery: Part 1704: Human body measurements (Anthropometric data)*.

Each anthropometric measurement is collected in isolation. It does not follow that a person who is at the 50th percentile for height is also at the 50th percentile for arm length or any other characteristic. Apertures for guards typically use 5th percentile data to ensure that the people with the narrowest body parts, such as fingers and limbs, cannot reach through. Separation and reach distances typically use 95th percentile data to ensure that the people with the longest body parts, such as fingers and limbs, cannot reach the hazard.

Anthropometric data can be used both for hazard identification to identify where guarding is required or is inadequate and risk control to design guarding.

Hazardous parts of machinery and plant pose a risk if they can be reached by any part of a worker's arms or legs. A risk assessment must often combine several anthropometric measurements such as the size of the space or aperture, for example to determine both if a finger, hand, forearm or entire arm can fit through and the distance to the danger point, for example to determine if it can be reached by a finger, hand, forearm or arm.

2. Separation distances

The following table can be used to assess risk within equipment and in the design and positioning of guards. The data is based on 'extreme case' situations. The separation values are based upon measurements of people with long arms, hands and fingers. The gaps are based on measurements of people with small diameter fingers and hands.

Where required, more detailed information may be found in Australian Standard, *AS 4024.1801 Safety of machinery: Part 1801: Safety distances to prevent danger zones being reached by the upper limbs*. Note that the anthropometric data used in this standard was based on available information at the time of the standard's development. Better sources may become available. The standard's data may need to be supplemented by actual measurements of the workforce if it differs significantly from the general Australian population.

Part of body	Gap (smallest dimension of any aperture or openings in the machinery or plant)	Minimum separation distance from danger zone
Fingertip	4 mm	2 mm
Finger	6 mm	120 mm
Arm	> 6 mm	900 mm
Arm (reaching above head)		2,700 mm

Note: If an arm can fit through a gap, the risk assessment should also consider any smaller apertures within the machinery or plant. If the arm can be bent at the elbow to reach into additional areas, the minimum separation distance from the elbow to that danger zone should be 550 mm. If the arm can be bent at the wrist to reach into additional areas, the minimum separation distance from the wrist to that danger zone should be 230 mm.

3. Location of distance guards

Distance guards should be at least 1,600 mm in height with a minimum separation distance of 900 mm. If the guard is between 1,000 mm and 1,600 mm in height, a minimum separation distance of 1,500 mm is required. Additional safety measures are also required for high risk hazards. No distance guards should be less than 1,000 mm in height.

Appendix 6 Manual handling risks

In reviewing the safety of machinery and plant including its guarding, the risks of manual handling injuries require consideration based on sound ergonomic principles. This includes consideration of:

- **the adequacy of the physical working environment** — for example whether frequently used displays, instruments or control panels are placed so operators can access them safely and maintain correct posture;
- **the type of plant or machinery** — for example whether use of the equipment exposes the operator or others to excessive vibration, noise or emissions or requires physical force to operate;
- **the work organisation** — for example the required output and/or the urgency of the work and number and duration of work breaks; and
- **the physical demands placed on the operator** — for example whether the work is repetitive and/or involves awkward movements or postures, or occurs in extremes of temperature.

See also the Commission's *Code of practice: Manual handling*, Resources Safety's *Manual tasks in mining fact sheet* series and, where required, Australian Standard, *AS 4204.1401 Safety of machinery — Ergonomic principles — Design principles — Terminology and general principles*.

Appendix 7 Risk assessment form

The form in this appendix can be used to identify hazards, assess their risks and identify controls to implement in relation to safeguarding of machinery and plant. This risk management process is outlined below.

Firstly, identify potential hazards. These may include:

- drawing-in or trapping hazards;
- entanglement hazards;
- shearing hazards;
- cutting hazards;
- impact hazards;
- crushing hazards;
- stabbing and puncturing hazards;
- friction and abrasion hazards;
- hot or cold hazards;
- ejection hazards;
- other contact hazards;
- noise hazards;
- release of hazardous substances;
- hazards related to location of the machine or plant;
- hazards related to systems of work associated with the machine or plant; and
- concurrent hazards.

Questions to ask to identify hazards

- Where fixed guards are provided, are they of substantial construction and secured into position while machinery is in operation?
- Where interlocked guards are provided, do they prevent operation of the machinery when open, and are the guards prevented from opening while the machinery is in operation?
- Where a presence-sensing system is used, does it operate as intended and stop the machinery when light beams or sensors are interrupted?
- Do guards protect against hazards at the rear and sides of machinery?
- Are pre-operational checks conducted to ensure safety features are in working order?
- Are adequate isolation procedures provided for maintenance?
- Are manufacturers' manuals available?
- Are machine controls protected to prevent unintentional operation, clearly marked and within easy reach of the operator?
- Are warning signs and decals clearly visible?
- Where it is not practicable to provide guarding and people are required to operate or pass close to dangerous moving parts, is a safe system of work in place to reduce risks?
- Is it practical to provide a higher level of guarding than currently provided?
- Are operators and maintenance workers adequately trained, familiar with the operation and set up of machinery and able to demonstrate safety features?

Secondly, assess the level of risk for identified potential hazards by:

1. gathering information about the hazard(s). Consult with relevant people, including workers;
2. working out the likelihood of an injury or harm occurring — consider how many people are likely to be exposed to the hazard and for how long. Take into account different situations or conditions that might exist at the workplace and could increase risk, such as changes to operations, inspection, cleaning, maintenance, servicing and repairs and new or inexperienced workers;
3. using the information you have gathered to assess the potential consequences of any injury or harm occurring from the hazard(s). For example, whether people die or suffer major, minor or negligible injuries; and
4. rating the risk, by using the risk rating table below to work out the level of risk associated with each hazard.

Risk rating table				
Likelihood of injury or harm to health ↓	Consequences of injury or harm to health ↓			
	Insignificant eg no injuries	Moderate eg first aid/medical treatment	Major eg extensive injuries	Catastrophic eg fatalities
Very likely	High	Extreme	Extreme	Extreme
Likely	Moderate	High	Extreme	Extreme
Moderate	Low	High	Extreme	Extreme
Unlikely	Low	Moderate	High	Extreme
Highly unlikely (rare)	Low	Moderate	High	High

Extreme = immediate action

Thirdly, once the risk has been assessed, where required, choose control measures to eliminate or reduce the risks.

In relation to controlling risks from unguarded machinery or plant, there are requirements for particular types of guarding according to the case. See Section 2.3 of this code and, as applicable, regulation 4.37(1)(f) and 4.29 of the OSH Regulations or regulation 6.2 of the MSI Regulations.



Government of **Western Australia**
Department of **Commerce**
Department of **Mines and Petroleum**

c o m m i s s i o n
for occupational
safety and health

MIAC

2009

ISBN 978-1-920836-39-9

ISBN 978-1-920836-40-5 (web)

Comprehensive work safety and health information,
provided by the Department of Commerce and the
Department of Mines and Petroleum can be found at:

www.worksafe.wa.gov.au

and **www.dmp.wa.gov.au/ResourcesSafety**

Westcentre 1260 Hay Street West Perth

PO Box 294 West Perth 6872

Telephone: 1300 307 877

Facsimile: (08) 9321 8973

Email: safety@commerce.wa.gov.au

Resources Safety Division

Department of Mines and Petroleum

Level 1, 303 Sevenoaks Street Cannington

Postal address: 100 Plain Street East Perth WA 6004

Telephone: (08) 9358 8002

Facsimile: (08) 9358 8000

Email: ResourcesSafety@dmp.wa.gov.au

National Relay Service: 13 36 77

This document is available on request in other formats
to assist people with special needs